

## OPERATING INSTRUCTIONS/MAIN SEAL REPLACEMENT

Page 1 of 2



### MIT / MITH TWISTMATE Series Connectors

**DESCRIPTION:** Manual Twist Connection Tool for Sealing Internal Threaded Ports.

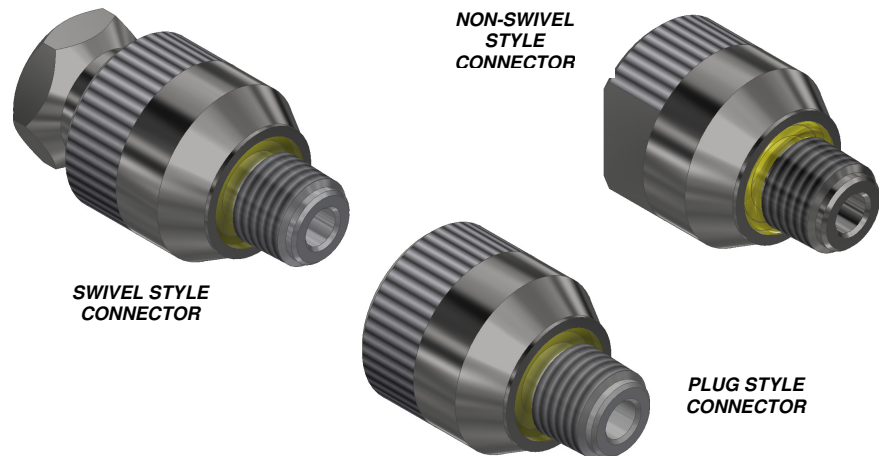

Please thoroughly read the instructions prior to operating the connector. The Twistmate connectors are designed to provide a safe, reliable leak-tight seal and connection when properly maintained and operated.

- The connector is designed to mate with a specific application. Verify the application prior to the introduction of pressure or processing. Use only in a safe environment. Safety chains and guards are recommended for all applications.
- Connectors are NOT designed for permanent connections and are for temporary connections only. Inadvertent loosening and loss of media may result when used as a permanent connection.
- Connectors are not internally valved and will not prevent loss of media when disconnected.

**DO NOT EXCEED pressure rating as marked on connector or corresponding literature.** Operating pressure rating based on tests using NPTF threads (to SAE J476a Dryseal specifications) of cold drawn steel. Material or thread deviations may reduce working pressure and should be verified by test.

- Installation
- Operation
- Main Seal Replacement
- Connector Maintenance
- Safety Warnings - Guidelines

### INSTALLATION:

1. This applies to the Swivel and Non-Swivel styles only.
2. **PLUG STYLE CONNECTORS DO NOT REQUIRE ANY INSTALLATION, THEY ARE SIMPLY A PLUG!**
3. Connect media hose/fitting to the termination port on connector.
  - a. Pipe tape and or thread sealant is recommended.
  - b. See chart below for termination torque ratings.
4. Female termination port on back end of connector.

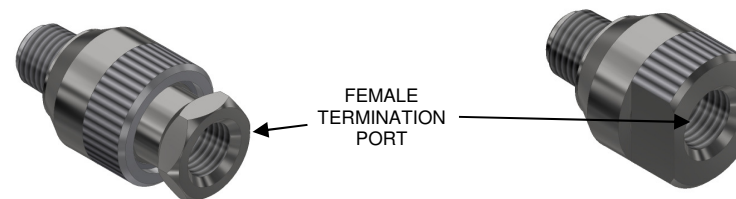

Termination Port Size	Torque lbs-ft
1/8 NPT	12
1/4 NPT	21
3/8 NPT	28
1/2 NPT	35
3/4 NPT	46
1 NPT	90
1-1/4 NPT	150
1-1/2 NPT	200

## OPERATING INSTRUCTIONS/MAIN SEAL REPLACEMENT

Page 2 of 2



### OPERATION:

1. Thread Twistmate connector finger-tight into test piece until main seal contacts test piece. This applies to all three styles.
2. **DO NOT WRENCH TIGHTEN!!!**

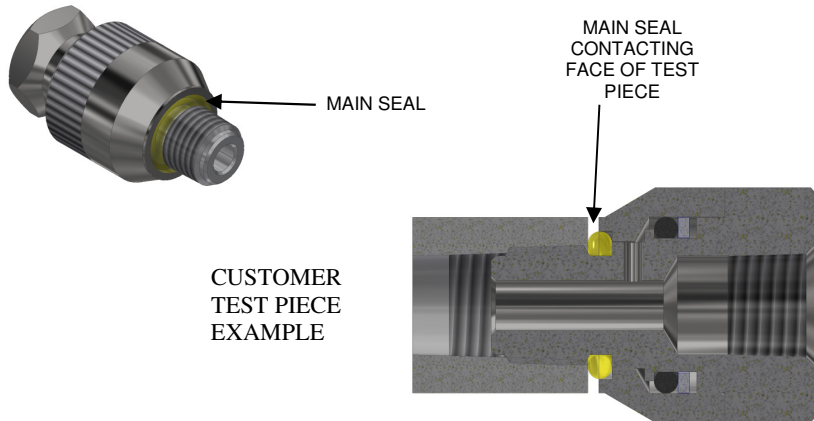

3. Activate test media and perform test. Test pressure will enhance the seal between test piece and Twistmate.
4. When test process is complete, deactivate/relieve the media pressure.
5. To disconnect from test piece, un-thread the Twistmate from the test port.

### MAIN SEAL REPLACEMENT:

1. Twistmate connectors do not require dis-assembly to replace main seal.
2. Using a pick like tool or small flat blade tool, remove main seal o-ring from front of sleeve on connector and discard.
3. Do not lubricate new main seal o-ring.
4. Roll o-ring over threads and make sure o-ring is seated in groove on body and into sleeve.

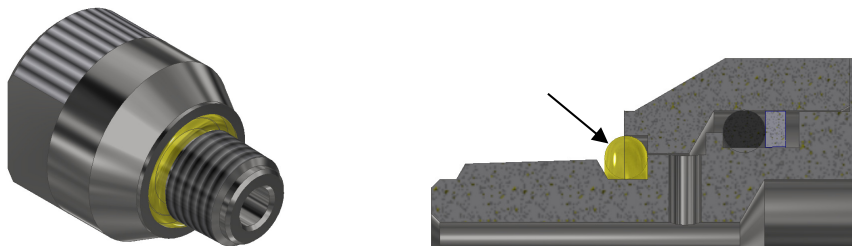

### BASIC BREAK DOWN OF THE MIT TWISTMATES:

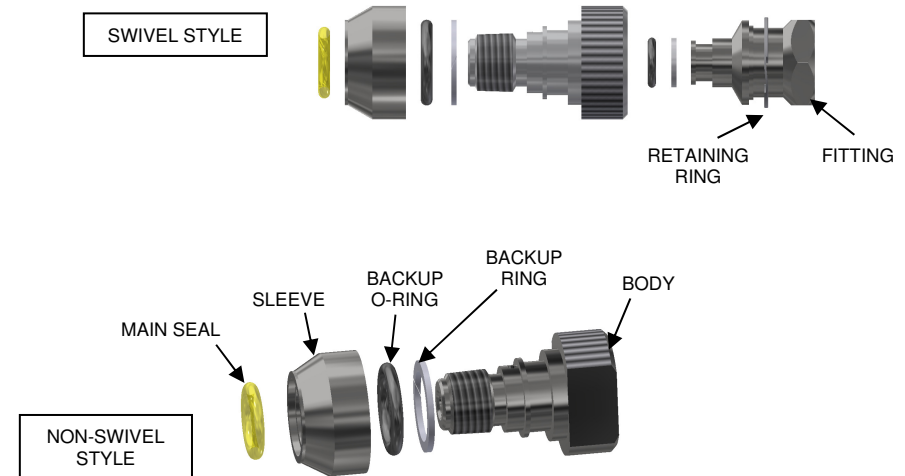

### CONNECTOR MAINTENANCE:

- A daily, weekly, and periodic inspection of the connector by competent person is recommended.
  - User must establish a regular interval for maintenance as determined by the user media and operational environment.
  - Inspection should include damage to the body missing or loose components, leak tightness, ease of operation, sufficient lubrication, wear, dirt accumulation and damage.
- Inspect threads for wear.
- Use only original **FasTest** spare parts that are designed for the application and are subject to strict quality control. See warranty.
- **FasTest** recommends a daily visual inspection of the main seal located in the front of the sleeve. Inspect for tears or cracks in the seal surface. Replace the main seal if tears or cracks are visible.
- Lubricate on regular intervals under normal operating conditions. Lubrication should be compatible with user application.

### FasTest, Inc. Product Warranty

FasTest, Inc. warrants its products against defects of workmanship and/or material for 1 YEAR from the date of the sale by FasTest, Inc. This warranty is void if the product is misused, tampered with, or used in a manner that is not in accordance with FasTest, Inc. recommendations and/or instructions. FasTest, Inc. is not liable for consequential or other damages including, but not limited to, loss, damage, personal injury, or any other expense directly or indirectly arising from the use of or inability to use its products either separately or in combination with other products. ALL OTHER WARRANTIES EXPRESSED OR IMPLIED, WHETHER ORAL OR WRITTEN, INCLUDING BUT NOT LIMITED TO WARRANTIES OR MERCHANTABILITY OR FITNESS FOR A PARTICULAR PURPOSE ARE EXPRESSLY EXCLUDED.

Remedy under this warranty is limited to replacement of the product or an account credit in the amount of the original selling price, at the option on FasTest, Inc. All allegedly defective products must be returned prepaid transportation to FasTest, Inc. along with information describing the products performance, unless disposition in the field is authorized in writing by FasTest, Inc.