

# GTEK AUTOMATION

A Division of Pacific Air Engineering, Inc.

26212 Dimension Drive, Suite 150, Lake Forest, CA 92630

Ph. 949-680-4242, Fax. 949-680-4243, www.gtek-automation.com

## Technical Data for:

**M00196-32A-12B,  
Micro 3 Air Pump**

Revision

1.0

Effective Date:

11/18/2013

### 1. Application:

\* These specifications apply to the DC Micro Air Pump M00196-32A-12B.

### 2. Test Environment:

2.1 The standard for environment test is the ambient temperature of 20°C and relative humidity of 65%RH. If no disputes occur, the test can be conducted under the following circumstance: the ambient temperature of 5-30°C and relative humidity of 40-85%RH.

2.2 Position: Horizontal

2.3 Load: Air pressure is 300 mmHg.

### 3. Rated condition:

3.1 Rated voltage: DC 12.0 V

3.2 Operating voltage range: DC 4.0 V ~ 13.0 V

3.3 Rated current: The highest current is less than 450 mA while pressurizing with DC 12.0 V from 0 to 300 mmHg.

3.4 Inflation time: It takes less than 8 seconds to pressurize from 0 to 300 mmHg in a 500CC tank.

3.5 Leakage: Pressurizing from 0 till 300±30 mmHg in a 500CC tank, then holding for 30 seconds. After that, measuring the dropped pressure value, which shall be less than 3 mmHg/min.

3.6 Noise: Putting a 5 cm sponge under the pump, and placing it about 30 cm away from the noise meter. The evaluated noise level shall be less than 65 dB while pressurizing with DC 12.0 V from 0 to 200 mmHg. (See Figure 1)

3.7 Maximum pressure: The maximum pressure value shall be more than 400 mmHg while pressurizing with DC 12.0 V in a 500CC tank from 0 till dead-head pressure value.

3.8 No load air flow: 3.5 LPM

3.9 Loaded air flow: 1.5 LPM @ 200 mmHG

3.10 Re-start voltage: It needs at least DC 6.0 V to re-start to pressurize pump to 300 mmHg while pressurization is stopped at 200 mmHg.

3.11 Operation temperature range: The temperature have to be between 5°C and 45°C and humidity must be between 30% and 80% RH to function the pump well.

3.12 Preservation temperature range: The temperature has to be between negative 20°C and positive 60°C and humidity has to be between 30% and 80% RH to keep the pump in a good condition.

### 4. Guaranteed performance:

\* After running through from test 4.1 to test 4.5, the leakage value shall be less than 10 mmHg/min. and noise level shall be less than 70 dB.

4.1 Low-temperature characteristic: Putting the pump in the temperature at negative 20°C for 72 hours; then taking it out and putting it in a room temperature at 20°C±5°C for two hours. Under this circumstance, running through test 3.3, 3.4, 3.7, 3.8, 3.9 and finding out that the pump still performs to specifications.

4.2 High-temperature characteristic: Putting the pump in the temperature at 60°C for 72 hours; then taking it out and putting it in a room temperature at 20°C±5°C for two hours. Under this circumstance, running through test 3.3, 3.4, 3.7, 3.8, 3.9 and finding out that the pump still performs to specifications.

4.3 High-temperature & High humidity: Putting the pump in the temperature at 60°C and the humidity at 90% for 72 hours; then taking it out and putting it in a room temperature at 20°C±5°C for two hours. Under this circumstance, running through test 3.3, 3.4, 3.7, 3.8, 3.9 and finding out that the pump still performs to specifications.

# GTEK AUTOMATION

A Division of Pacific Air Engineering, Inc.

26212 Dimension Drive, Suite 150, Lake Forest, CA 92630

Ph. 949-680-4242, Fax. 949-680-4243, www.gtek-automation.com

## Technical Data for:

**M00196-32A-12B,  
Micro 3 Air Pump**

Revision

1.0

Effective Date:

11/18/2013

4.4 Temperature & humidity cycle test: After doing the temperature and humidity cycle test, -20°C x 2Hr → +25°C x 1Hr → +60°C 85%RH x 2Hr → 25°C x 1Hr, for twelve times, the pump shall still perform the same functions proved by running through test 3.3, 3.4, 3.7, 3.8 and 3.9.

4.5 Performance test: In a 500CC tank, pressurizing for 10 seconds, deflating for 5 seconds as one cycle. Doing it for 50,000 times, then examine the pump by test 3.3, 3.4, 3.7, and 3.8 and figure out that the pump is still in a good function.

### 5. Thermal test performance:

\* After the pump has been tested through test 5.1 and 5.2, it must be suitable the basic performance required by item 3.4 to 3.9. However the current is allowed lower than 450mA and the noise performance can not be guaranteed.

5.1 Low-temperature environment test: Under a temperature of 5°C for 5 hours, then examining the pump by test 3.4, 3.5, 3.6, 3.7, 3.8 and 3.9 and finding out it still perform well.

5.2 High-temperature environment test: Under a temperature of 45°C for 5 hours, then examining the pump by test 3.4, 3.5, 3.6, 3.7, 3.8 and 3.9 and finding out it still perform well.

### 6. Other:

6.1 The lead tension: No abnormality occurs when a 0.5 kg static load is hanging in the parallel direction of the lead wire for one minute.

6.2 Unusual test: There is no burning and smoking occurrence while the power is on with DC 12.0 V for 8 hours continuously.

6.3 Appearance: The appearances of the pump shall not contain cracks and impurities.

6.4 Label:

Vendor:	GTEK AUTOMATION
Phone No.:	Ph. 949-680-4242
Part No.:	P/N M00196-32A-12B
Description/Voltage:	Micro 3, 12VDC
Serial No.:	S/N 000000

6.5 Motor terminal for Soldering process the heat temp is controlled by 330°C, and operating time is for 3 sec only.

6.6 Do not use PVC tubing to plumb the air outlet. When ABS connects to PVC it gets brittle easily. We advise to use polyurethane or silicone tubing.

7. In case, any modifications, additions, or eliminations on this specifications are necessary, decisions shall be made through the negotiations between our customers and GTEK AUTOMATION.

8. Acceptable standard: Acceptable standard is according to the MIL-STD-105D.

#### SPECIAL INSPECTION LEVELS

LOT SIZE	S4	
2-15	A	2
16-25	B	3
26-90	C	5
91-150	D	8
151-500	E	13
501-1200	F	20
1201-10000	G	32

# GTEK AUTOMATION

A Division of Pacific Air Engineering, Inc.

26212 Dimension Drive, Suite 150, Lake Forest, CA 92630

Ph. 949-680-4242, Fax. 949-680-4243, www.gtek-atuomation.com

## Technical Data for:

**M00196-32A-12B,  
Micro 3 Air Pump**

Revision

1.0

Effective Date:

11/18/2013

### 9. Structural drawing and material list:

#### Material List:

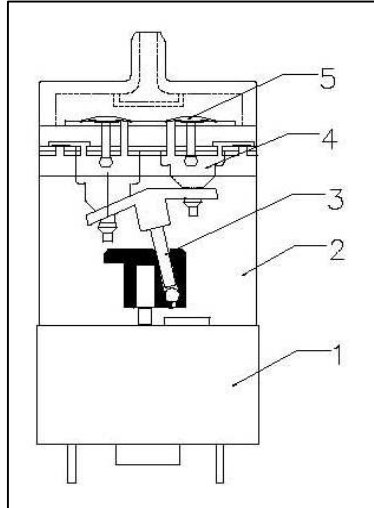

#### No./Item/Description

1. RoHS Motor: DC 12.0 V
2. Plastic: ABS (PA-757)
3. Pin: Stainless Steel (SUS420-J2)
4. Diaphragm: Rubber (CR-499A44)
5. Umbrella: Rubber (CR-498A55)

#### Noise Test:

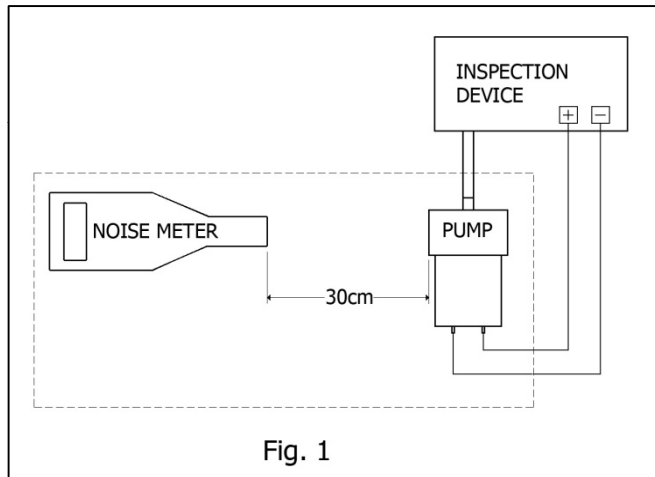

# GTEK AUTOMATION

A Division of Pacific Air Engineering, Inc.

26212 Dimension Drive, Suite 150, Lake Forest, CA 92630

Ph. 949-680-4242, Fax. 949-680-4243, www.gtek-automation.com

Technical Data for:

M00196-32A-12B,  
Micro 3 Air Pump

Revision

1.0

Effective Date:

11/18/2013

10. Finished product drawing: (Undefined Tolerance +/- 0.5mm)

