

GTEK AUTOMATION

A Division of Pacific Air Engineering, Inc.

MODEL GTA-40RNS (BRUSH LESS TYPE) AIR/VACUUM PUMP

TECHNICAL DATA

P/N:	GTA-40RNS-BL-12VDC-DB1	GTA-40RNS-BL-24VDC-DB1
Voltage:	12VDC	24VDC
Rated Current:	6.5 A	5.5 A
Open Flow Air Output:	* 1.41 CFM (40 LPM)	
Max. Vacuum	-25.59 InHg (-650 mmHg)	
Max. Pressure	14 PSI (1 Bar)	100 PSI (7 Bar)
Dimensions:	6.29" L x 7.00" H x 4.60" W (160mm L x 178mm H x 117mm W)	
Weight:	8.37 LBS (3.8 Kg)	
Motor Type	DC Motor, Brush Less Type, Ins. Class E	
Connection Type:	1/4" Female NPT Inlet and Outlet Air Ports	
Driver Type:	Internal	

* Approx. Flow Rates.



BLDC - Single head type

Output Air Flow

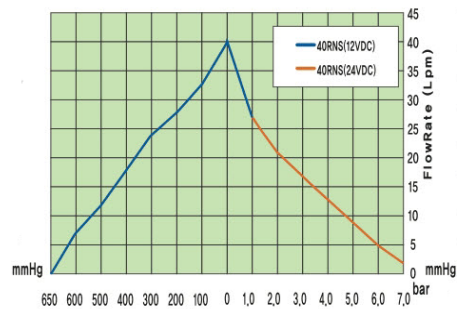

Internal driver type : 40RNS

■ Drawing

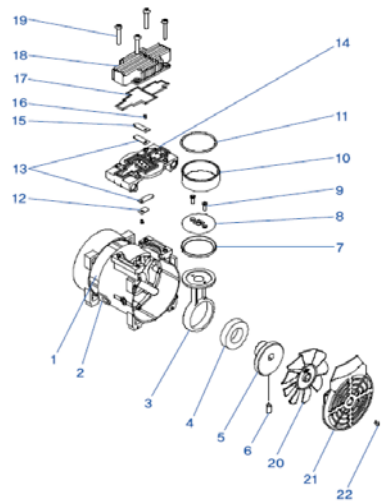
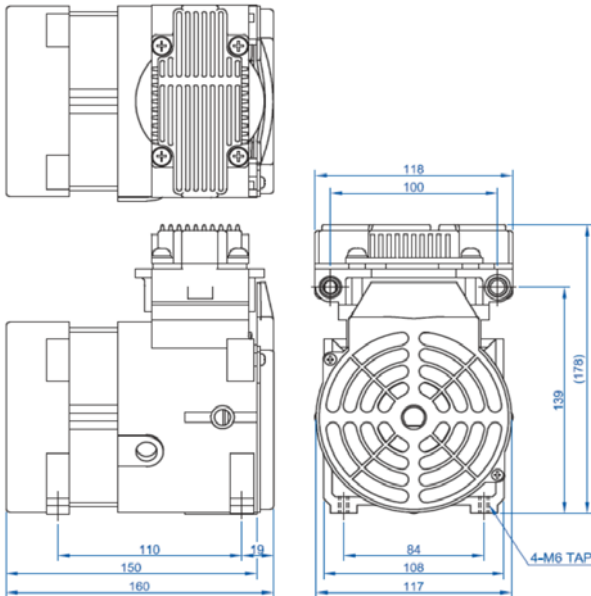

No.	Description	Material	Q'ty	Remarks
1	Motor (BLDC Version)		1	110 Core
2	Wire Holder	NBR	1	
3	Rod	ADC 12	1	
4	Bearing		1	6006ZZ
5	Eccentric		1	
6	Set Screw		1	M6
7	Teflon Cup	PTFE	1	
8	Rod Cap	ADC 12	1	
9	Rod Screw	STS	2	M4
10	Cylinder	AL6061	1	Anodizing
11	O-Ring	Silicone	1	
12	Valve washer	STS	1	Small
13	Valve	STS	2	
14	Valve Plate	ADC 12	1	
15	Valve washer	STS	1	Large
16	Valve Screw		2	M4
17	Rec-Ring	Silicone	1	Red
18	Head Cap	ADC 12	1	
19	Head Screw		4	M6
20	Fan	P,P	1	Black
21	Fan Cover	P,C	1	Black
22	F/C Screw		2	M4

Applied Model : 40, 50, 60, 70RNS(RVS, RAS)

GTEK AUTOMATION

A Division of Pacific Air Engineering, Inc.

26212 Dimension Drive, Suite 150, Lake Forest, CA 92630

Ph. 949-680-4242, Fax. 949-680-4243, Email: Sales@Gtek-Automation.com

Web Site: Gtek-Automation.com