

INSTALLATION AND OPERATING INSTRUCTIONS

Standard and Connection Verification versions: read and understand each of the following procedures before operating the connector:

- A. Installation of Seals
- B. Mounting the Connector
- C. Attachment of Pilot Pressure and Test Media Supply Lines
- D. Connector Operation

A. Installation of Seals

1. For seal install or replacement loosen set screw (1) on side of housing.
2. Unscrew (counterclockwise) and remove seal casing (2). NOTE: A spanner wrench hole (3) is provided for breaking the seal casing loose if required.

Note: Seal sets contain elastomer seals and washers. For complete listing of seal set size ranges see catalog.

3. Seal set contains elastomer seals and washers. Verify that seals and washers are the same size. Assemble seal set (4) into seal casing (2) per Figure 3.
4. Reassemble and tighten seal casing (2) with seal set (4) to housing.
5. Retighten set screw (1).

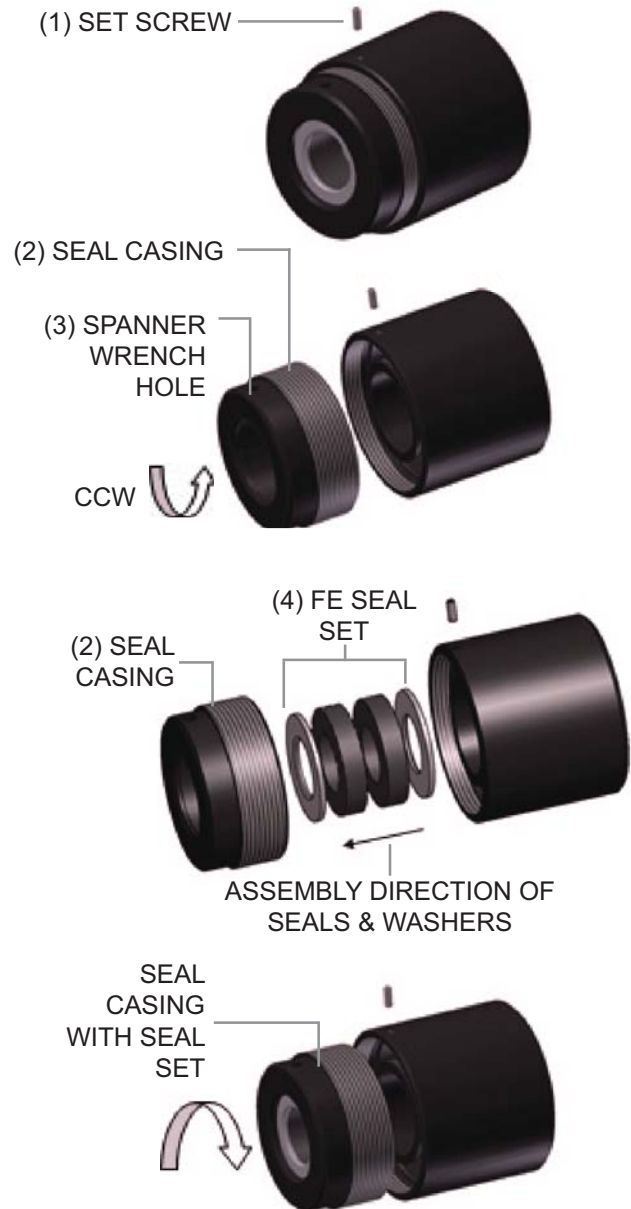

Figure 3. Installation of Seals

B. Mounting the Connector

The connector must be secured to the test piece with a mechanical or other device to assure the connector is not uncoupled from the test piece by the uncoupling force of the test itself. The securing or holding device may be a fixture, clamp, cylinder or other appropriate means that prevents ejection of the test piece from the connector.

Uncoupling force example:

Test piece has a ½" O.D. and is tested at 100 psi maximum. Uncoupling force = area (πr^2) x pressure = $\pi(.25)^2 \times 100 \approx 20$ lbs. Secured device should be designed to withstand this force and include an adequate margin for safety. Do not activate the connector without an adequate and safe securing mechanism.

Mount the FE connector to the fixture or appropriate device using either threaded mounting holes on the rear of the connector body, or appropriate adapter.

C. Attachment of Pilot Pressure and Test Media Supply Lines

1. Attach pilot pressure line to pilot port (E) from Figure 4
 Note: A regulated pneumatic source is required to maximize seal life and assure optimum seal ability for the application. The pilot pressure should be minimized to maintain sealing on the test piece without excessive compression of the seal.
2. Attach test media line to test port (D) from Figure 4.
3. Provide a means whereby test pressure will not be introduced until the pilot pressure required to seal is reached. The means should also provide quick exhaust of test pressure in the event pilot pressure falls below the minimum required to seal.

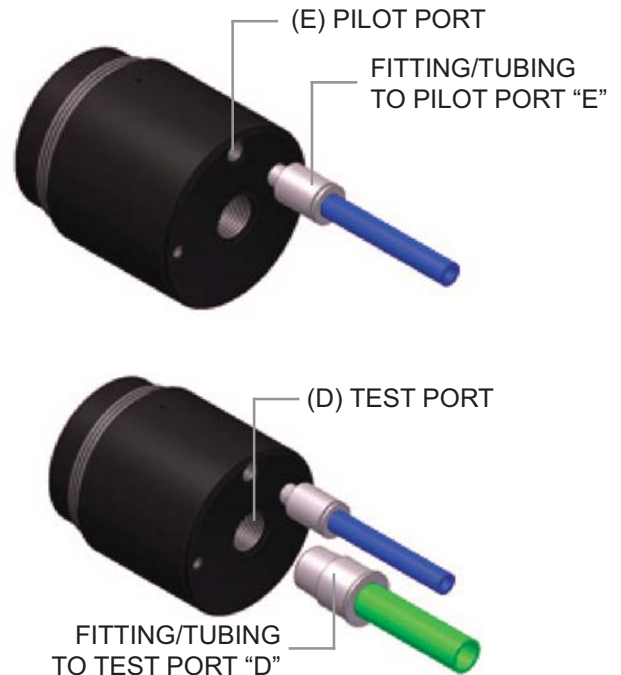
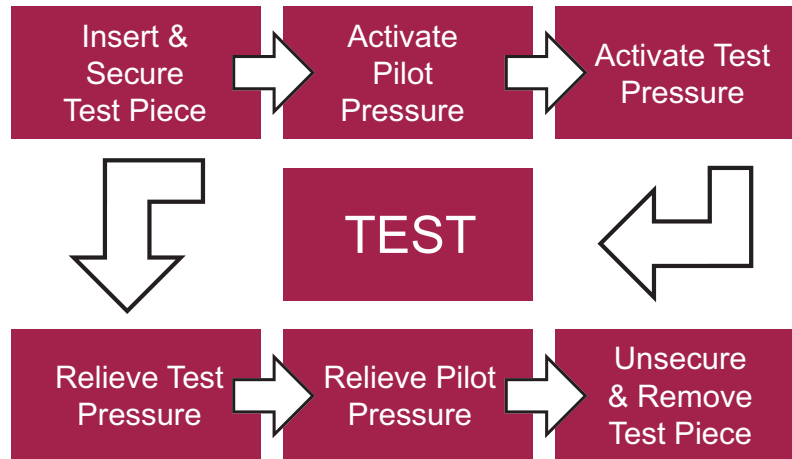

Figure 4. Attachment of Pilot and Media Lines

Connector Operation

FasTest recommends that both the FE connector and the test piece are secured by mechanical devices before proceeding with the following sequence:

Activate connector testing sequence as shown below.



1. Insert test piece into the end of the connector and secure. Make sure the test piece is inserted to the required minimum insertion length. This will assure proper location relative to the seals. Make sure the connector and test piece are secure.
2. Apply pilot pressure to seal against the part. Generally, a 60 to 90 psi pneumatic pilot pressure source is required. Additional pilot pressure may be required for contoured surfaces (i.e., threads etc...). See FasTest catalog for Pilot Pressure Booster. CAUTION: Do not activate PILOT or TEST PRESSURE without test piece in place.
3. With pilot activated, introduce gas or liquid through the FasTest FE connector.
4. Perform testing operation.
5. Relieve test pressure.
6. Relieve pilot pressure.
7. Remove test piece.

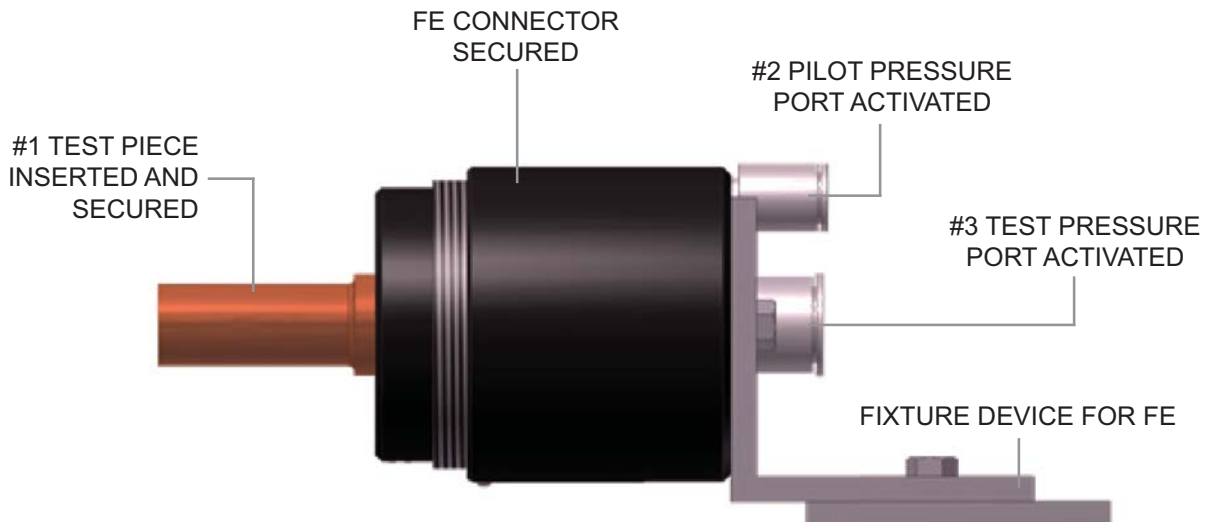

Figure 9. Fixture and Operation