

LINEAR

Ac0920



MOTOR FREE
PISTON SYSTEM



Airflow & Power Consumption

Specifications

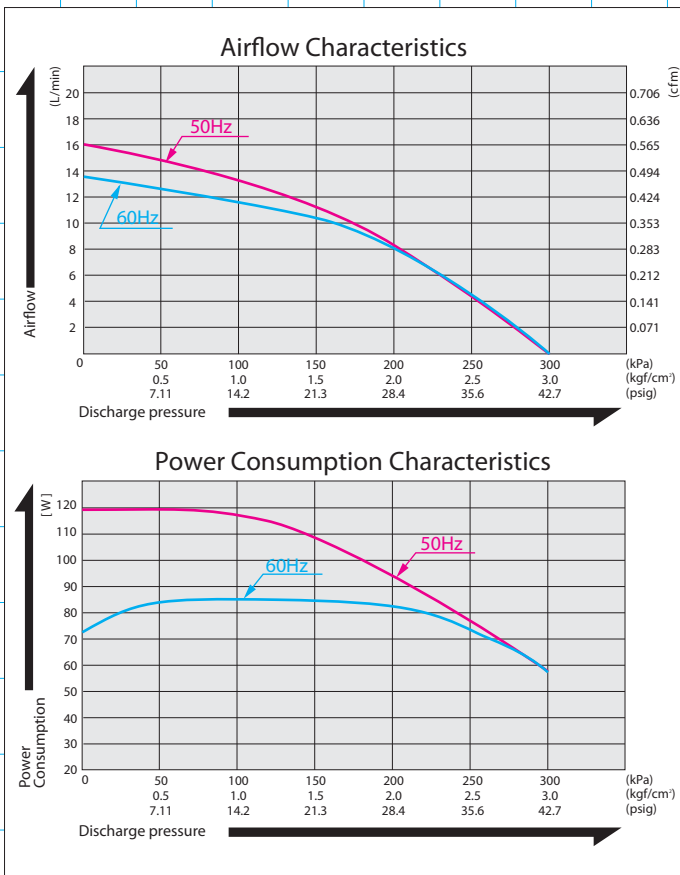

	(SI)	(EURO)	(U.S.A.)
Rated Pressure	200 kPa {2.0 kgf/cm ² }	2.0 bar	29 psig
Rated Airflow	8 L/min 0.283 cfm		
Rated Voltage	115 V AC or 230 V AC		
Maximum Pressure	300 kPa {3.0 kgf/cm ² }	3.0 bar	43.5 psig
Power Consumption	81 W or 100 W		
Rated Frequency	60 Hz or 50 Hz		
Life Expectancy	3,000 hours		
Outlet	ISO Rc 1/4		
Duty Cycle	30 minutes		
Coil Insulation Class	E or its equivalent (JETL)		
Mounting Dimensions	102 (L) x 130 (W) mm	4" (L) x 5-1/8" (W)	
Gross Weight	5 kg	11 Lbs.	
Leadwire Length	150 mm	5-7/8" for 115V	

Please read the page of "How to Use This Catalog" first for correct use of compressors and pumps.

Application Examples

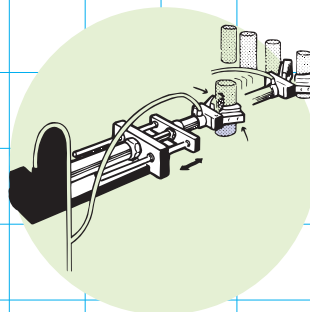

Air Cylinder/Chuck Driver

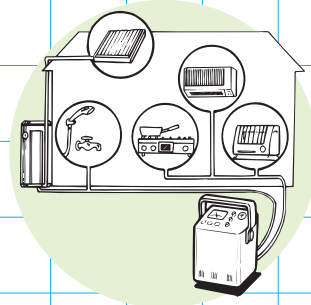

Leakage Tester

Sketch Drawing and Mounting Dimensions Diagram (mm)

