

# LINEAR

# AC0110



MOTOR FREE  
PISTON SYSTEM



## Airflow & Power Consumption

## Specifications

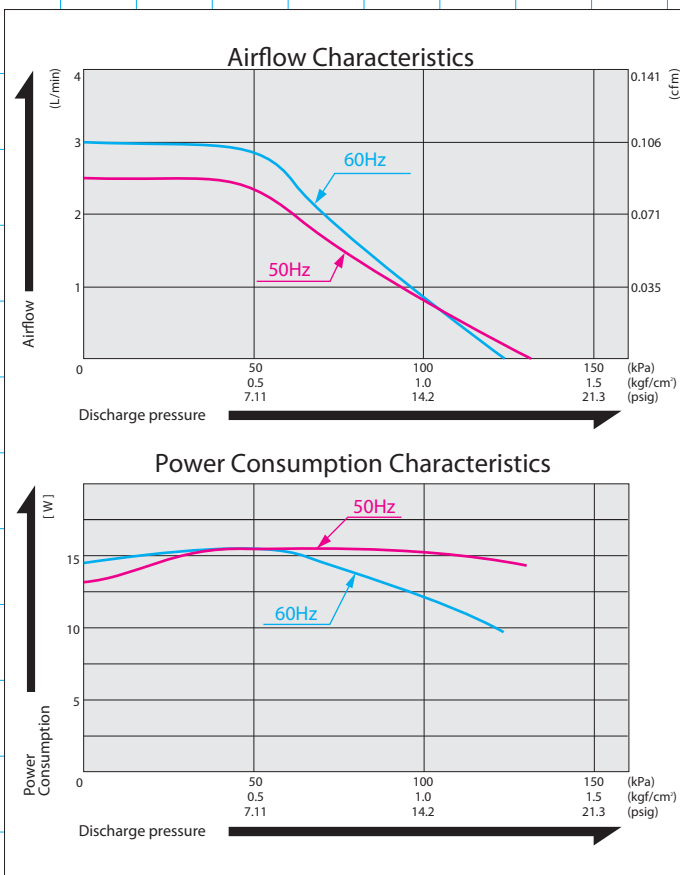

|                       | (SI)                                    | (EURO)                   | (U.S.A.)  |
|-----------------------|---|--------------------------|-----------|
| Rated Pressure        | 100 kPa {1.0 kgf/cm <sup>2</sup> }      | 1.0 bar                  | 14.5 psig |
| Rated Airflow         | 0.8 L/min                               |                          |           |
| Rated Voltage         | 115 V AC or 230 V AC                    |                          |           |
| Maximum Pressure      | 120 kPa {1.2 kgf/cm <sup>2</sup> }      | 1.2 bar                  | 17.4 psig |
| Power Consumption     | 12 W or 15 W                            |                          |           |
| Rated Frequency       | 60 Hz or 50 Hz                          |                          |           |
| Life Expectancy       | 4,000 hours                             |                          |           |
| Outlet                | 6 mm O.D. hose nipple                   |                          |           |
| Duty Cycle            | 30 minutes                              |                          |           |
| Coil Insulation Class | E or its equivalent (JETL) and B for UL |                          |           |
| Mounting Dimensions   | 48 (L) x 62 (W) mm                      | 1-7/8" (L) x 2-7/16" (W) |           |
| Gross Weight          | 0.7 kg                                  | 1.54 Lbs.                |           |
| Leadwire Length       | 200 mm                                  | 7-7/8"                   |           |

Please read the page of "How to Use This Catalog" first for correct use of compressors and pumps.

## Application Examples

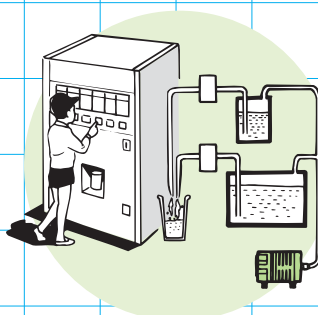

Automatic Dispenser

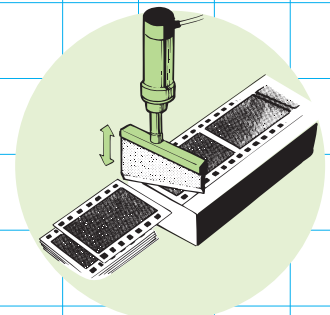

Film Cutter

## Sketch Drawing and Mounting Dimensions Diagram (mm)

