

LINEAR

AC0105



MOTOR FREE
PISTON SYSTEM



Airflow & Power Consumption

Specifications

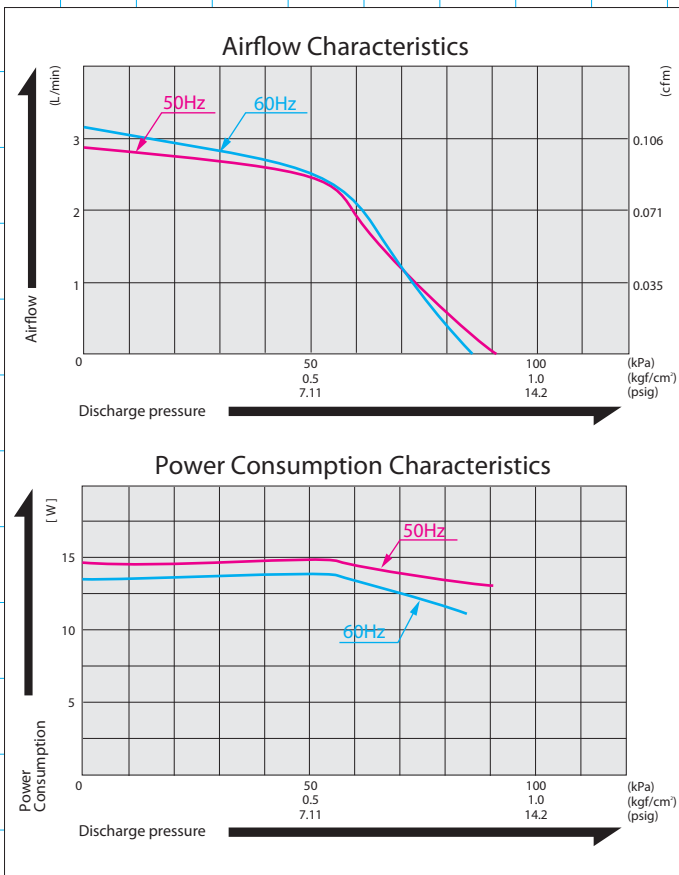

	(SI)	(EURO)	(U.S.A.)
Rated Pressure	50 kPa (0.5 kgf/cm ²)	0.5 bar	7.25 psig
Rated Airflow	2.5 L/min		
Rated Voltage	115 V AC or 230 V AC		
Maximum Pressure	80 kPa (0.8 kgf/cm ²)	0.8 bar	11.6 psig
Power Consumption	14 W or 15 W		
Rated Frequency	60 Hz or 50 Hz		
Life Expectancy	5,000 hours		
Outlet	6 mm O.D. hose nipple		
Duty Cycle	60 minutes		
Coil Insulation Class	E or its equivalent (JETL) or B for UL		
Mounting Dimensions	48 (L) x 62 (W) mm	1-7/8" (L) x 2-7/16" (W)	
Gross Weight	0.7 kg	1.54 Lbs.	
Leadwire Length	200 mm	7-7/8"	

Please read the page of "How to Use This Catalog" first for correct use of compressors and pumps.

Application Examples



Saline Water Splasher

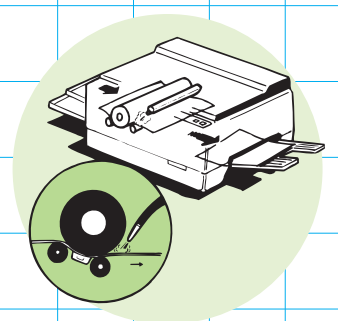

Copy Paper Separator

Sketch Drawing and Mounting Dimensions Diagram (mm)

