

PC2 Series

Combinations 1/8" and 1/4"

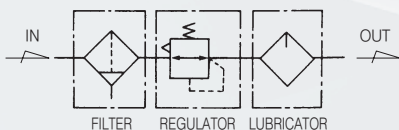

Symbol



Standard Specifications

Fluid	Air	
Max. operating pressure (MPa)	1.0(140psi)	
Proof pressure (MPa)	1.5(200psi)	
Set pressure range (MPa)	Standard	0.05 ~ 1.0(7~140psi)
	Made to order specifications	0.05~0.2(7~30psi), 0.05~0.4(7~60psi)
Ambient and fluid temperature (°C)	-5 ~ 60(23~140°F) (Non-freezing)	
Flow capacity ※ (Nℓ/min)	1/8"	1,000(35scfm)
	1/4"	1,300(46scfm)
Filtration (μm)	5	
Construction	Relieving style	
Recommended oil	ISO VG32 (Turbine oil 1 class)	
Port size for pressure gauge (Rc (PT), NPT)	1/8"	
Weight (kg)	0.49(1.08lb)	

※ Test conditions : Supply pressure 0.7Mpa(100psi), Set pressure 0.6Mpa(90psi)

How to order

PC 2 A — * 02 D G — * — C1M1Z

Series
(Combination Units)

Components

Blank	Filter-Regulator-Lubricator
A	Piggyback-Lubricator
B	Filter-Regulator
C	Filter-Coalescing Filter(0.3)-Regulator
D	Piggyback-Coalescing Filter(0.3)
E	Filter-Coalescing Filter(0.01)-Regulator
F	Piggyback-Coalescing Filter(0.01)

Thread

Blank	Rc(PT)
N	NPT
G	G(PF)

Port size

01	1/8
02	1/4

Drain Options

Blank	Manual Push Drain
D	Auto Drain (N.O Type)
D2	Auto Drain (Piping exhaust)
D5	Manual Drain (Piping exhaust)

Note1)

Note1) Min.operating pressure is 0,15MPa (20psi) for Auto Drain (N.O Type)

Pressure Gauge

Symbol	Description	Pressure range
Blank	None	
G	Integral pressure gauge (W/Limit Indicator)	1,0MPa(140psi)
P	Pressure gauge	1,0MPa(140psi)
P2	Pressure gauge	0,2MPa(30psi)
P4	Pressure gauge	0,4MPa(60psi)

Accessories

Symbol	Port size	Description	Applicable series
C1	1/8"	Check Valve	PC2~PC3
C2	1/4"		PC2~PC4
C3	3/8"		PC4
M1	1/8"	Modular Manifold Block Kit	PC2~PC3
M2	1/4"		PC2~PC4
M3	3/8"		PC4
V	-	Lock-out Valve	PC2~PC5
W	-	Modular pipe adapter Kit	PC2~PC5
Z	-	Pressure Switch	PC2~PC5

* Refer to page 62 for how to attach bracket & how to combine the accessories
* When specifying more than one symbol, indicate them alphabetically Ex) CIM1Z

Other Options

Blank	Set at 0 to 1,0 MPa, 5μm(140psi) (Standard)		
2	Set at 0 to 0,2 MPa(30psi)	K	Built-in Check Valve
4	Set at 0 to 0,4 MPa(60psi)	R	Flow direction : Right → Left
E	Non-relieving type	T	Tamper Resistant Kit
J2	Filter element - 20μm	U	Regulator (Top mounted)
J4	Filter element - 40μm	XC16	Copper-free

Note2) Refer to page 85 for Built-in Check valve, Tamper resistant kit.
Note3) Separately packed, Not assembled.

* If ordering more than one option, indicate symbols numerically then alphabetically Ex) 2EK
* Over Max. pressure value can be set.

■ Construction

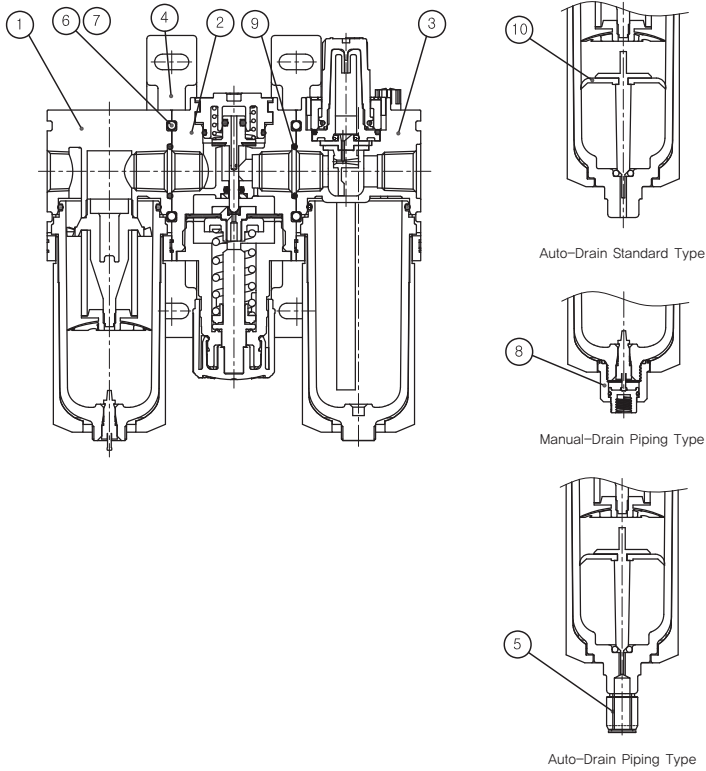

Main Parts / Parts List

No.	Description	Material	Remarks
①	Filter ass'y	-	
②	Regulator ass'y	-	
③	Lubricator ass'y	-	
④	Bracket ass'y	-	
⑤	Fitting	-	
⑥	Connecting screw	Carbon steel	
⑦	Connecting nut	Carbon steel	
⑧	Manual-drain pipe Ass'y	-	

Replacement Parts / Parts List

No.	Description	Material	Part No.
⑨	Combination O-ring	NBR	AN015-01
⑩	Auto-drain ass'y	-	PF2-26A002-01

■ PC2 Dimensions

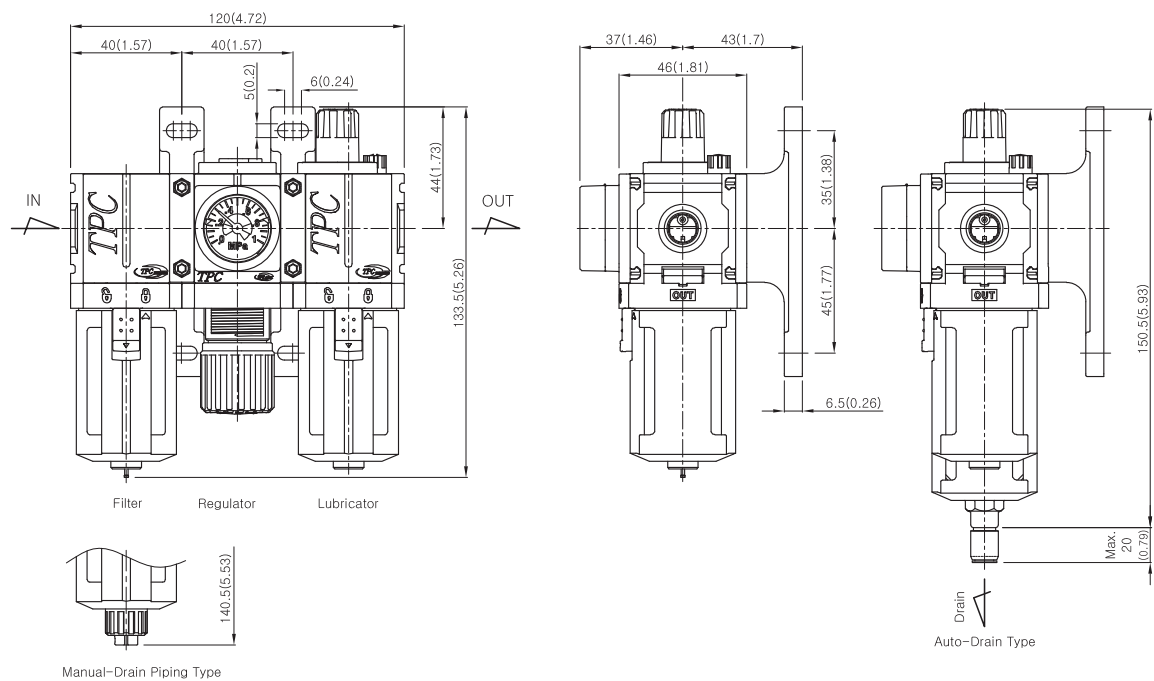

PC2 Series

Combinations 1/8" and 1/4"

■ PC2A Dimensions

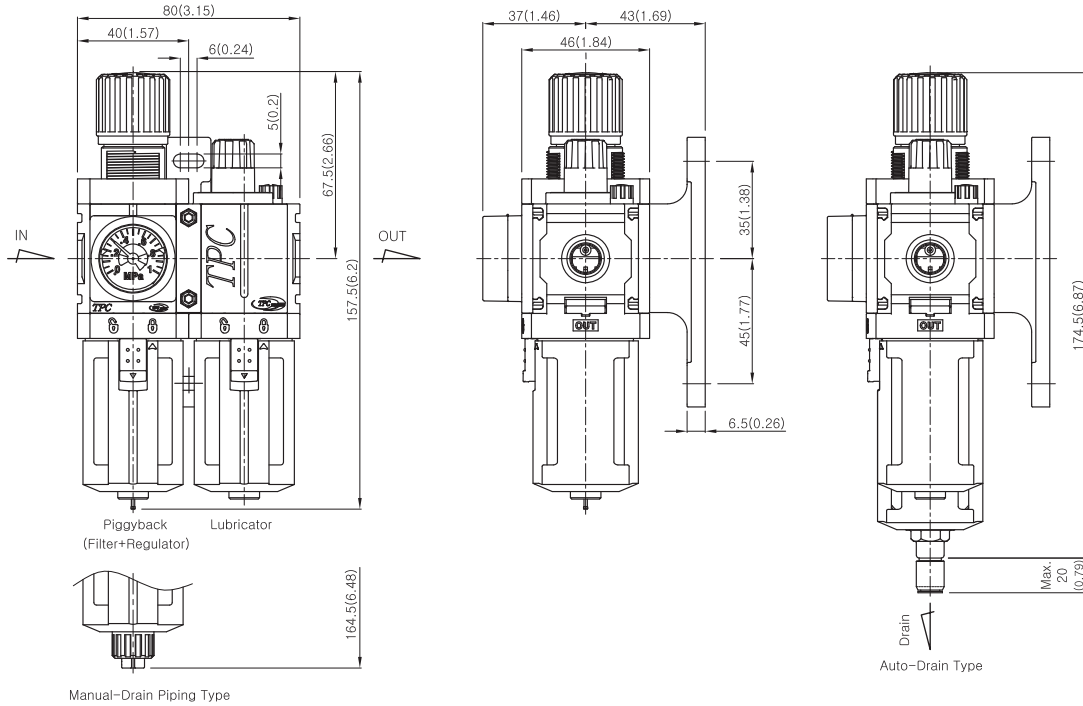

■ PC2B Dimensions

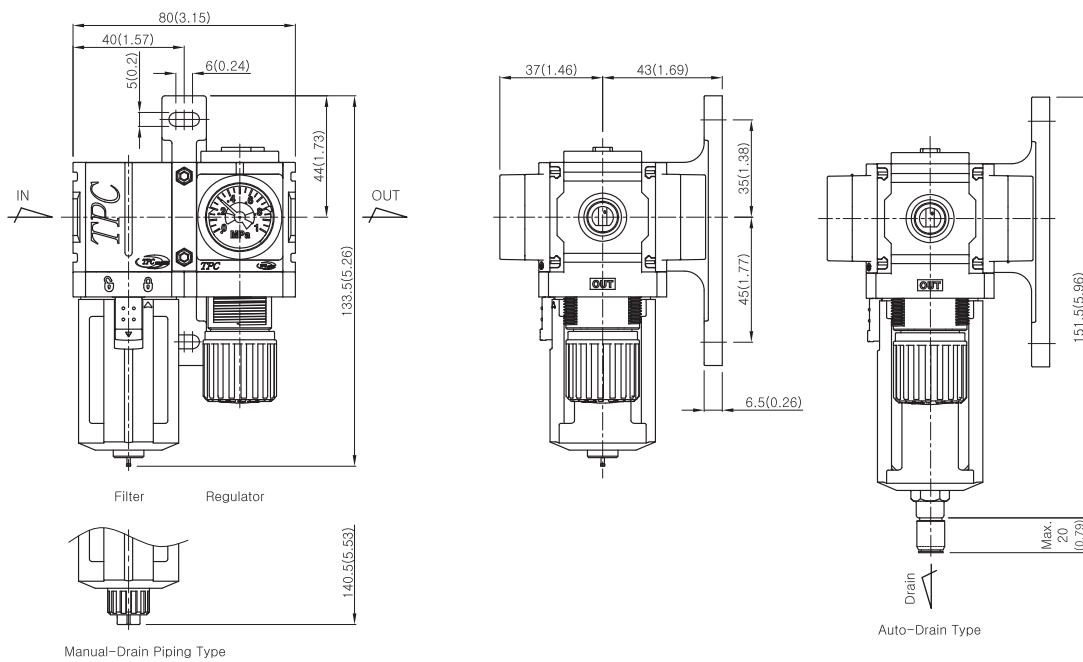

■ PC2 Series Flow Characteristics

▶ 1/8" PC2

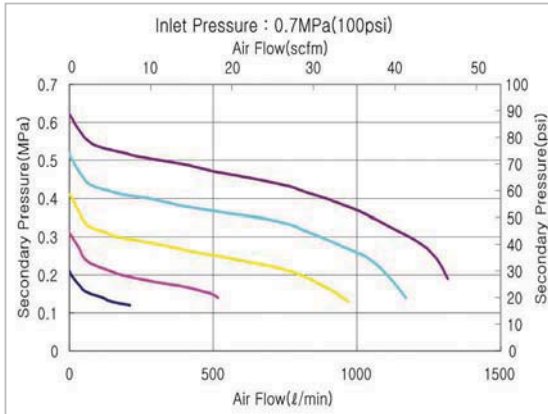

▶ 1/4" PC2

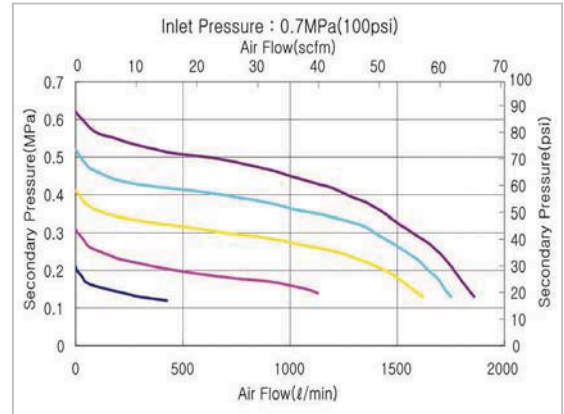

▶ 1/8" PC2A

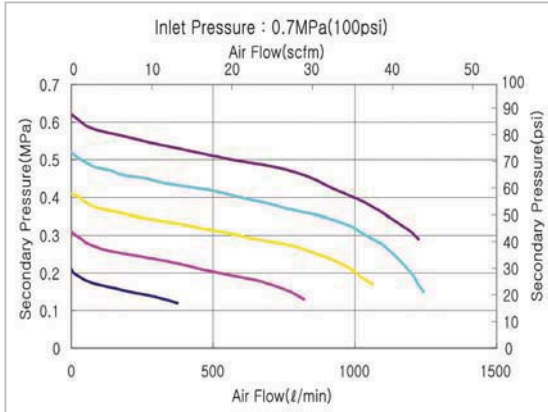

▶ 1/4" PC2A

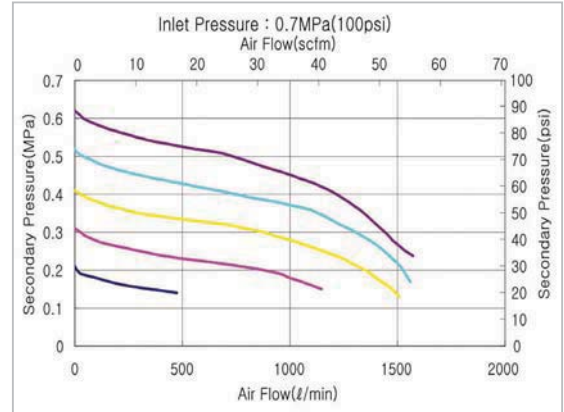

PC3 Series

Combinations 1/4" and 3/8"

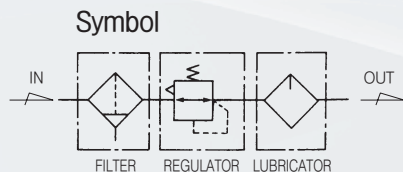

Standard Specifications

Fluid	Air	
Max. operating pressure (MPa)	1.0(140psi)	
Proof pressure (MPa)	1.5(200psi)	
Set pressure range (MPa)	Standard	0.05 ~ 1.0(7~140psi)
	Made to order specifications	0.05 ~ 0.2(7~30psi) 0.05 ~ 0.4(7~60psi) 0.05 ~ 1.2(7~170psi)
Ambient and fluid temperature (°C)	-5~60(23~140°F) (Non-freezing)	
Flow capacity ※ (Nℓ /min)	1/4"	1,700(60scfm)
	3/8"	2,400(85scfm)
Filtration (μm)	5	
Construction	Relieving style	
Recommended oil	ISO VG32 (Turbine oil 1 class)	
Port size for pressure gauge (Rc (PT), NPT)	1/8"	
Weight (kg)	0.99(1.08lb)	

※ Test conditions : Supply pressure 0.7 MPa(100psi), Set pressure 0.6 MPa(90psi)

How to order

PC 3 A — * 03 D G — * — C1M1Z

Series
(Combination Units)

Components

Blank	Filter-Regulator-Lubricator
A	Piggyback-Lubricator
B	Filter-Regulator
C	Filter-Coalescing Filter(0,3)-Regulator
D	Piggyback-Coalescing Filter(0,3)
E	Filter-Coalescing Filter(0,01)-Regulator
F	Piggyback-Coalescing Filter(0,01)

Thread

Blank	Rc(PT)
N	NPT
G	G(PF)

Port size

02	1/4
03	3/8

Drain Options

Blank	Manual Push Drain
D	Auto Drain (N.O Type)

Note1)

Note1) Min.operating pressure is 0,15MPa (20psi) for Auto Drain (N.O Type)

Pressure Gauge

Symbol	Description	Pressure range
Blank	None	
G	Integral pressure gauge (W/Limit Indicator)	1,0MPa(140psi)
P	Pressure gauge	1,0MPa(140psi)
P2	Pressure gauge	0,2MPa(30psi)
P4	Pressure gauge	0,4MPa(60psi)

Accessories

Symbol	Port size	Description	Applicable series
C1	1/8"	Check Valve	PC2~PC3
C2	1/4"		PC2~PC4
C3	3/8"		PC4
M1	1/8"	Modular Manifold Block Kit	PC2~PC3
M2	1/4"		PC2~PC4
M3	3/8"		PC4
V	-	Lock-out Valve	PC2~PC5
W	-	Modular pipe adapter Kit	PC2~PC5
Z	-	Pressure Switch	PC2~PC5

* Refer to page 62 for how to attach bracket & how to combine the accessories

* When specifying more than one symbol, indicate them alphabetically Ex) CIMIZ

Other Options

Blank	Set at 0 to 1,0 MPa(140psi), 5μm (Standard)			
2	Set at 0 to 0,2 MPa(30psi)	K	Built-in Check Valve	Note2)
4	Set at 0 to 0,4 MPa(60psi)	R	Flow direction : Right → Left	
12	Set at 0 to 1,2 MPa(170psi)	T	Tamper Resistant Kit	Note2,3)
E	Non-relieving type	U	Regulator (Top mounted)	
J2	Filter element - 20μm	XC16	Copper-free	
J4	Filter element - 40μm			

Note2) Refer to page 85 for Built-in Check valve, Tamper resistant kit, Note3) Separately packed, Not assembled.

* If ordering more than one option, indicate symbols numerically then alphabetically Ex) 2EK

* Over Max. pressure value can be set.

■ Construction

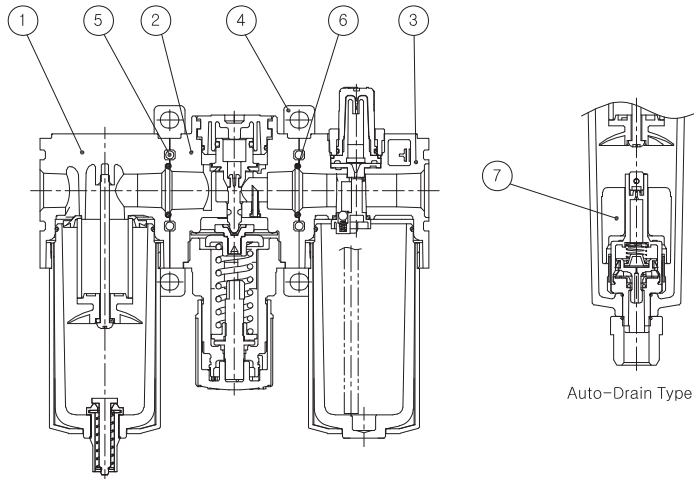

Main Parts / Parts List

No.	Description	Material	Remarks
①	Filter ass'y	-	
②	Regulator ass'y	-	
③	Lubricator ass'y	-	
④	Bracket ass'y	Aluminum	
⑤	Connecting screw	Carbon steel	

Replacement Parts / Parts List

No.	Description	Material	Part No.
⑥	Combination O-ring	NBR	TAR4000-07-6001
⑦	Auto-drain ass'y	-	TAF3000-04A-6008

■ PC3 Dimensions

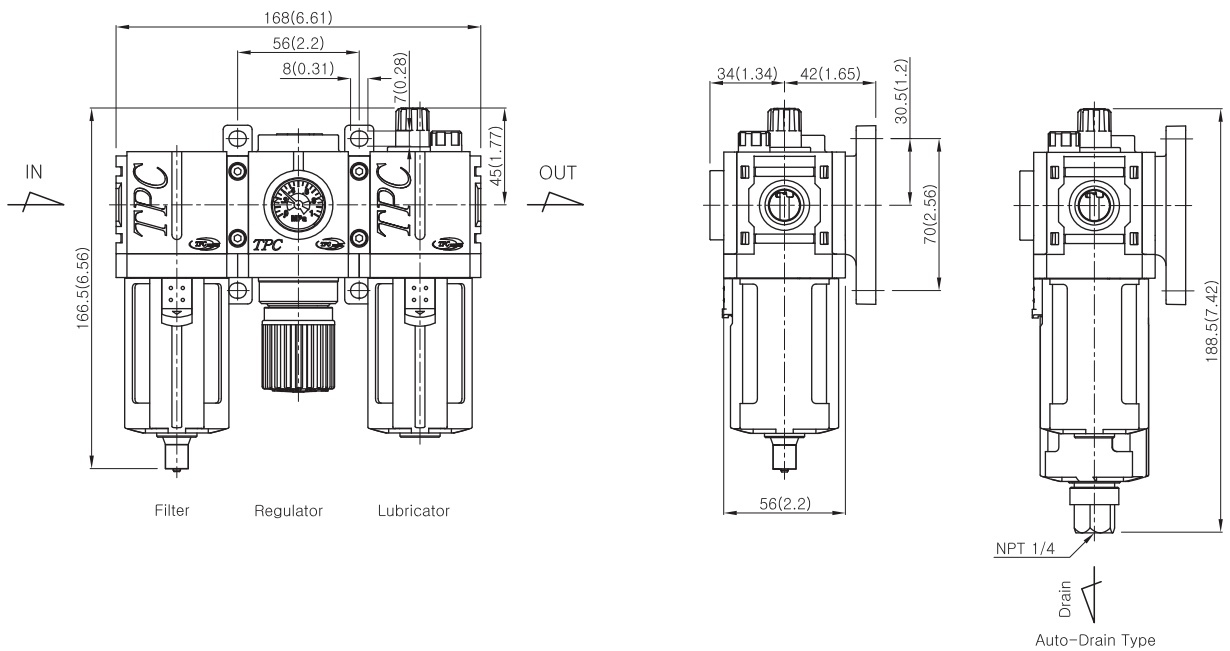

PC3 Series

Combinations 1/4" and 3/8"

PC3A Dimensions

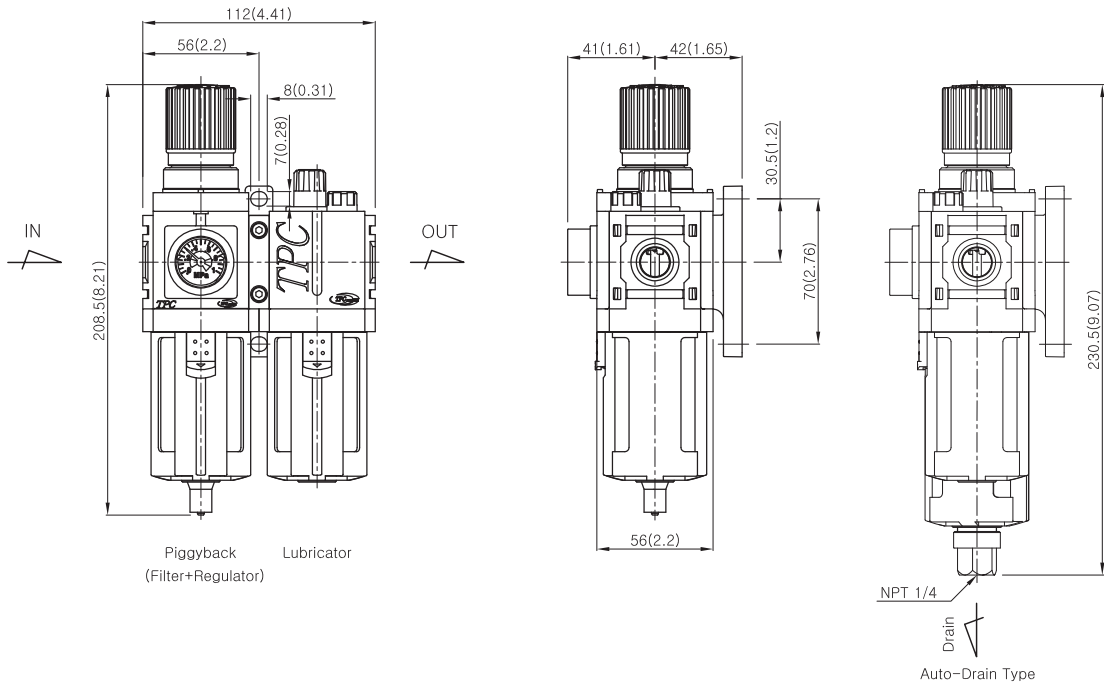

PC3B Dimensions

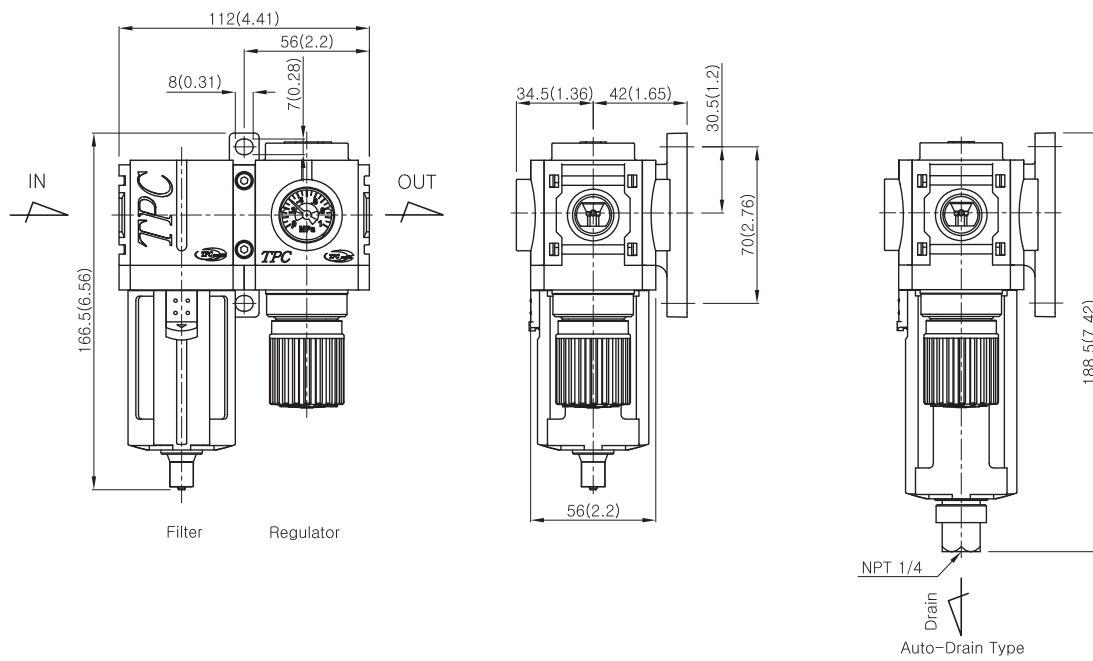

■ PC3 Series Flow Characteristics

▶ 1/4" PC3

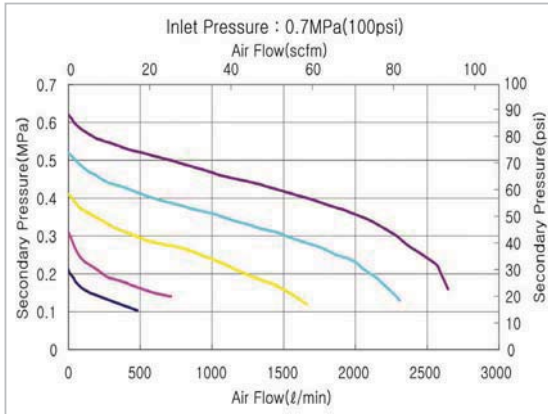

▶ 3/8" PC3

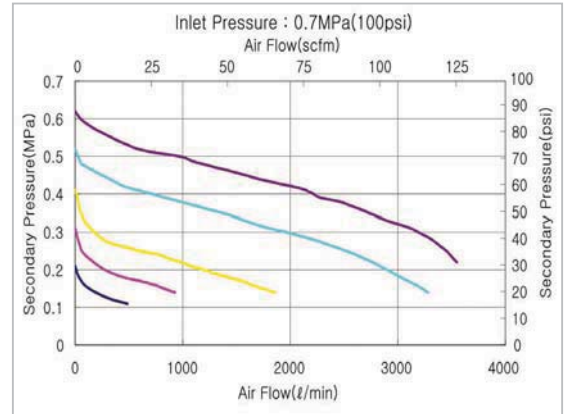

▶ 1/4" PC3A

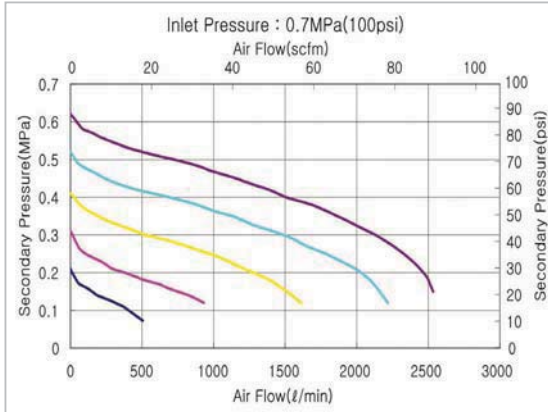

▶ 3/8" PC3A

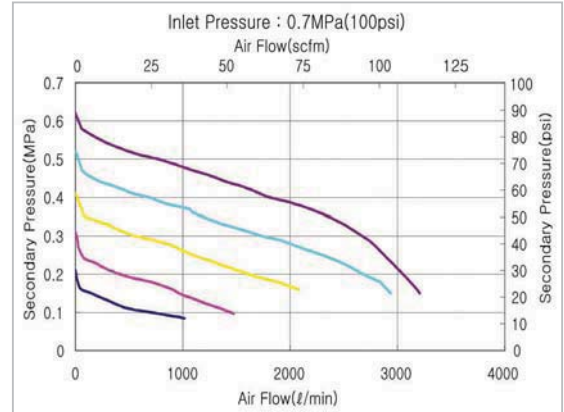

PC4 Series

Combinations 3/8" and 1/2"

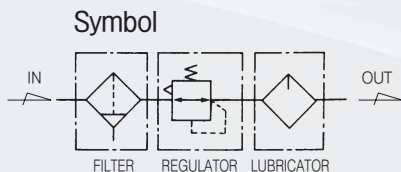

Standard Specifications

Fluid	Air	
Max. operating pressure (MPa)	1.0(140psi)	
Proof pressure (MPa)	1.5(200psi)	
Set pressure range (MPa)	Standard	0.05 ~ 1.0(7~140psi)
	Made to order specifications	0.05 ~ 0.2(7~30psi) 0.05 ~ 0.4(7~60psi) 0.05 ~ 1.5(7~200psi)
Ambient and fluid temperature (°C)	-5~60(23~140°F) (Non-freezing)	
Flow capacity ※ (Nℓ /min)	3/8"	2,800(99scfm)
	1/2"	4,300(152scfm)
Filtration (μm)	5	
Construction	Relieving style	
Recommended oil	ISO VG32 (Turbine oil 1 class)	
Port size for pressure gauge (Rc (PT), NPT)	1/8"	
Weight (kg)	1.88(4.14lb)	

※ Test conditions : Supply pressure 0.7 MPa(100psi), Set pressure 0.6 MPa(90psi)

How to order



Blank	Filter-Regulator-Lubricator
A	Piggyback-Lubricator
B	Filter-Regulator
C	Filter-Coalescing Filter(0,3)-Regulator
D	Piggyback-Coalescing Filter(0,3)
E	Filter-Coalescing Filter(0,01)-Regulator
F	Piggyback-Coalescing Filter(0,01)

Blank	Rc(PT)
N	NPT
G	G(PF)

03	3/8
04	1/2

Blank	Manual Push Drain
D	Auto Drain (N.O Type)

Note1)

Note1) Min.operating pressure is 0,15MPa (20psi) for Auto Drain (N.O Type)

Symbol	Description	Pressure range
Blank	None	
G	Integral pressure gauge (W/Limit Indicator)	1,0MPa(140psi)
P	Pressure gauge	1,0MPa(140psi)
P2	Pressure gauge	0,2MPa(30psi)
P4	Pressure gauge	0,4MPa(60psi)

Accessories

Symbol	Port size	Description	Applicable series
C1	1/8"	Check Valve	PC2~PC3
C2	1/4"		PC2~PC4
C3	3/8"		PC4
M1	1/8"	Modular Manifold Block Kit	PC2~PC3
M2	1/4"		PC2~PC4
M3	3/8"		PC4
S	-	Slow Start Valve	PC4
V	-	Lock-out Valve	PC2~PC5
W	-	Modular pipe adapter Kit	PC2~PC5
Z	-	Pressure Switch	PC2~PC5

* Refer to page 62 for how to attach bracket & how to combine the accessories
* When specifying more than one symbol, indicate them alphabetically Ex) C3M3Z

Other Options

Blank	Set at 0 to 1,0 MPa(140psi), 5μm (Standard)		
2	Set at 0 to 0,2 MPa(30psi)	K	Built-in Check Valve
4	Set at 0 to 0,4 MPa(60psi)	L	Life Indicator
15	Set at 0 to 1,5 MPa(200psi)	R	Flow direction : Right → Left
E	Non-relieving type	T	Tamper Resistant Kit
J2	Filter element - 20μm	U	Regulator (Top mounted)
J4	Filter element - 40μm	XC16	Copper-free

Note2) Refer to page 85 for Built-in Check valve, Tamper resistant kit, Note3) Separately packed, Not assembled.

* If ordering more than one option, indicate symbols numerically then alphabetically Ex) 2EK

* Over Max. pressure value can be set.

■ Construction

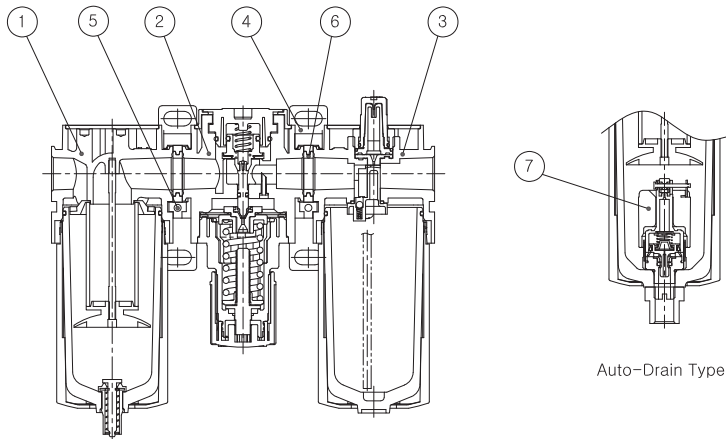

Main Parts / Parts List

No.	Description	Material	Remarks
①	Filter ass'y	-	
②	Regulator ass'y	-	
③	Lubricator ass'y	-	
④	Bracket ass'y	Aluminum	
⑤	Connecting screw	Carbon steel	

Replacement Parts / Parts List

No.	Description	Material	Part No.
⑥	Spacer O-ring	NBR	PC4A-04-001-01
⑦	Auto-drain ass'y	-	TAF3000-04A-6008

Auto-Drain Type

■ PC4 Dimensions

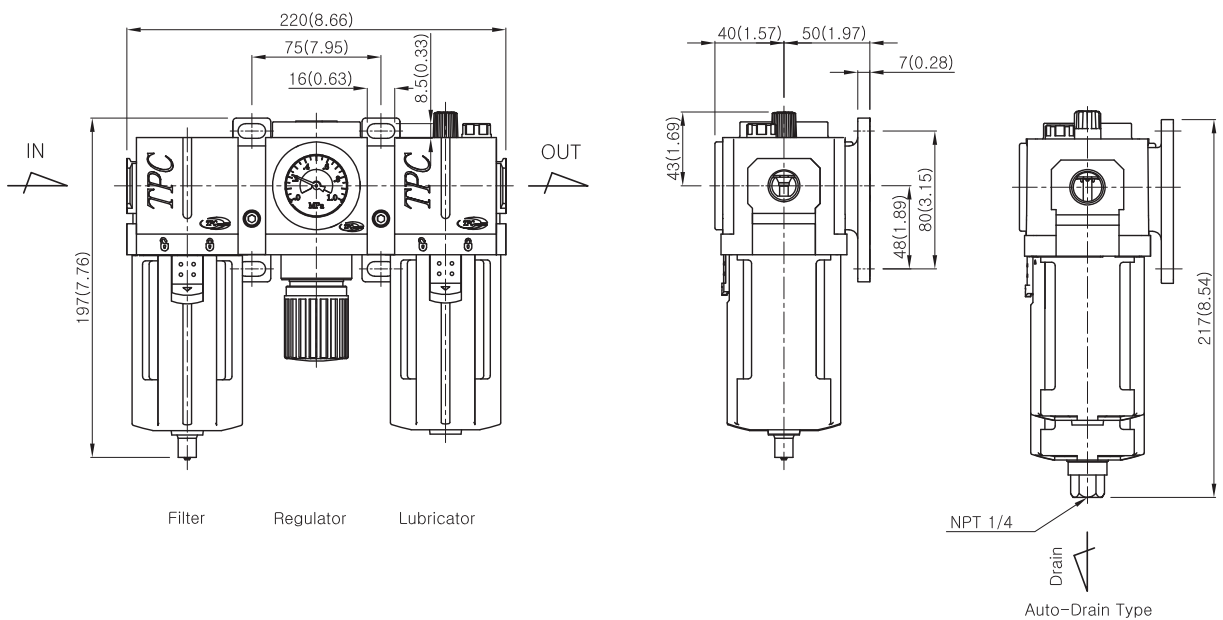

PC4 Series

Combinations 3/8" and 1/2"

PC4A Dimensions

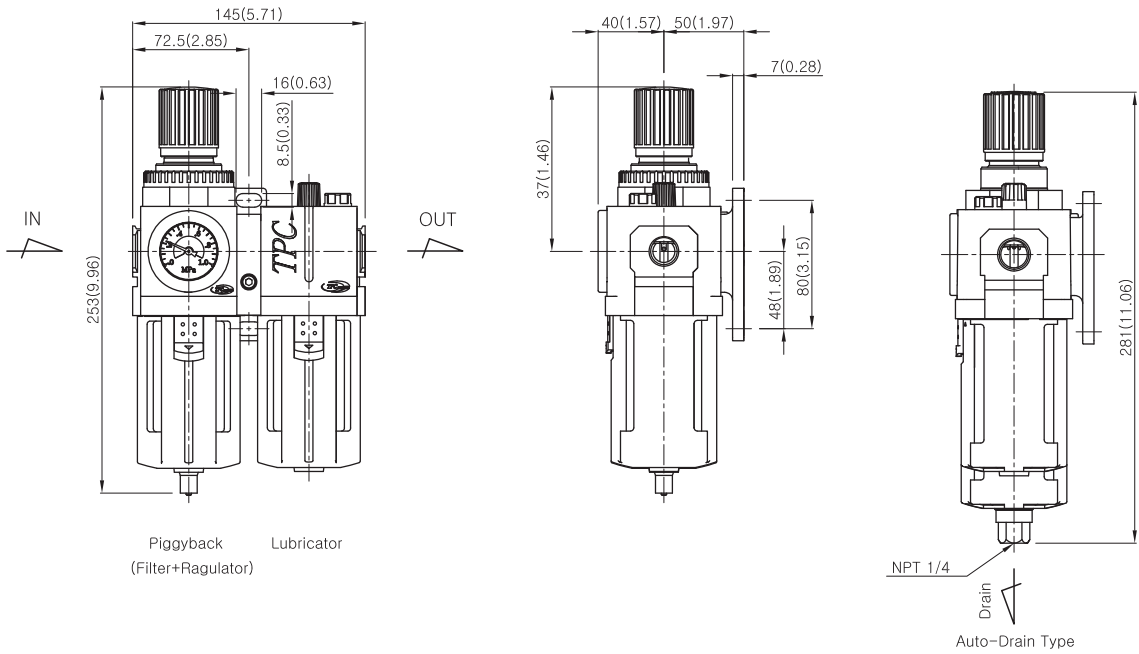

PC4B Dimensions

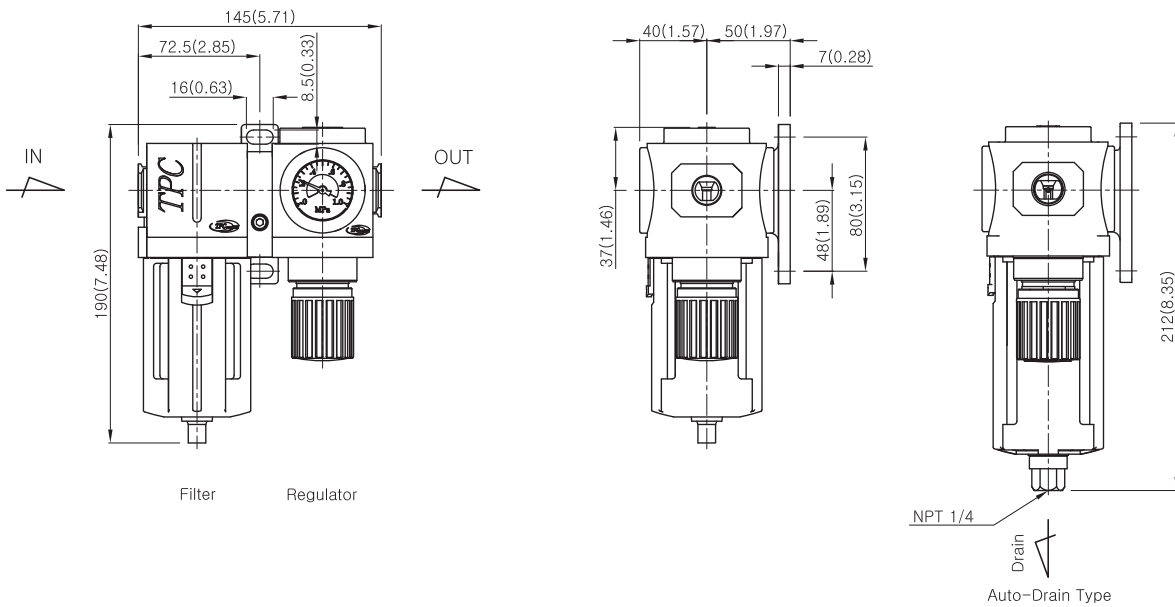

■ PC4 Series Flow Characteristics

▶ 3/8" PC4

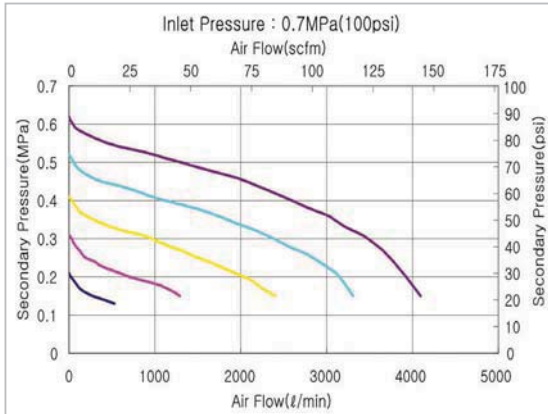

▶ 1/2" PC4

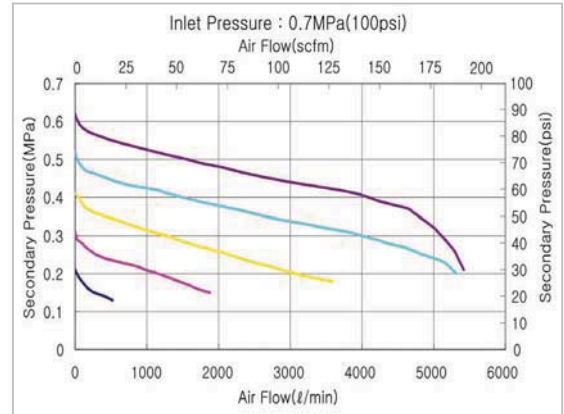

▶ 3/8" PC4A

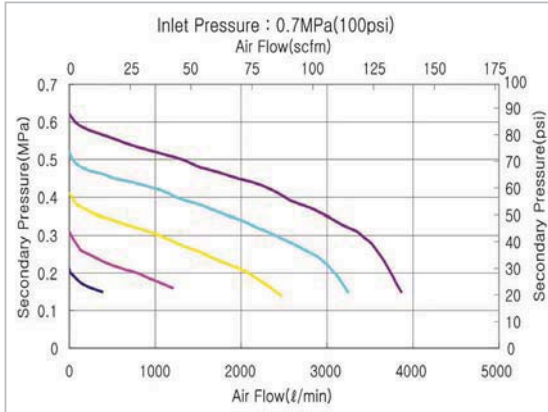

▶ 1/2" PC4A

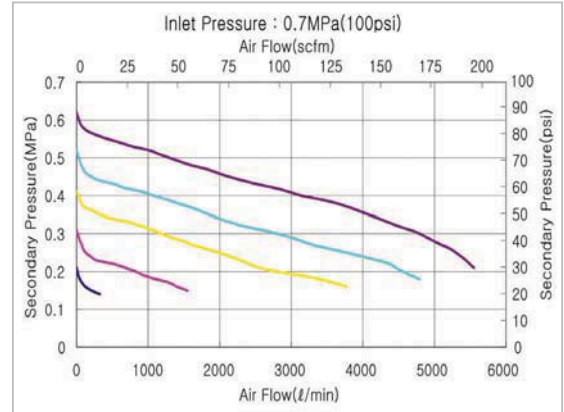

PC5 Series

Combinations 3/4" and 1"

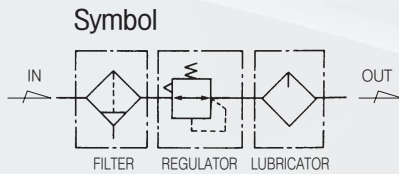

Standard Specifications

Fluid	Air	
Max. operating pressure (MPa)	1.0(140psi)	
Proof pressure (MPa)	1.5(200psi)	
Set pressure range (MPa)	Standard	0.05 ~ 1.0(7~140psi)
	Made to order specifications	0.05 ~ 0.2(7~30psi) 0.05 ~ 0.4(7~60psi) 0.05 ~ 1.5(7~200psi)
Ambient and fluid temperature (°C)	-5~60(23~140°F) (Non-freezing)	
Flow capacity ※ (Nℓ /min)	1/4"	5,700(201scfm)
	3/8"	6,100(215scfm)
Filtration (μm)	5	
Construction	Relieving style	
Recommended oil	ISO VG32 (Turbine oil 1 class)	
Port size for pressure gauge (Rc (PT), NPT)	1/8"	
Weight (kg)	4.06(8.95lb)	

※ Test conditions : Supply pressure 0.7 MPa(100psi), Set pressure 0.6 MPa(90psi)

How to order

PC 5 A — * 10 D G — * — VWZ

Series (Combination Units) → PC 5 A

Components → * 10 D G

Blank	Filter-Regulator-Lubricator
A	Piggyback-Lubricator
B	Filter-Regulator
C	Filter-Coalescing Filter(0,3)-Regulator
D	Piggyback-Coalescing Filter(0,3)
E	Filter-Coalescing Filter(0,01)-Regulator
F	Piggyback-Coalescing Filter(0,01)

Thread → *

Blank	Rc(PT)
N	NPT
G	G(PF)

Port size → *

06	3/4
10	1

Drain Options → *

Blank	Manual Push Drain
D	Auto Drain (N.O Type)

Pressure Gauge → *

Blank	None
G	Integral pressure gauge (W/Limit Indicator)
P	Pressure gauge
P2	Pressure gauge
P4	Pressure gauge

Accessories → VWZ

Symbol	Port size	Description	Applicable series
C1	1/8"	Check Valve	PC2~PC3
C2	1/4"		PC2~PC4
C3	3/8"		PC4
M1	1/8"	Modular Manifold Block Kit	PC2~PC3
M2	1/4"		PC2~PC4
M3	3/8"		PC4
V	-	Lock-out Valve	PC2~PC5
W	-	Modular pipe adapter Kit	PC2~PC5
Z	-	Pressure Switch	PC2~PC5

Accessories

Symbol	Port size	Description	Applicable series
C1	1/8"	Check Valve	PC2~PC3
C2	1/4"		PC2~PC4
C3	3/8"		PC4
M1	1/8"	Modular Manifold Block Kit	PC2~PC3
M2	1/4"		PC2~PC4
M3	3/8"		PC4
V	-	Lock-out Valve	PC2~PC5
W	-	Modular pipe adapter Kit	PC2~PC5
Z	-	Pressure Switch	PC2~PC5

※ Refer to page 62 for how to attach bracket & how to combine the accessories
 ※ When specifying more than one symbol, indicate them alphabetically Ex) VWZ

Other Options

Blank	Set at 0 to 1.0 MPa(140psi), 5μm (Standard)		
2	Set at 0 to 0.2 MPa(30psi)	K	Built-in Check Valve
4	Set at 0 to 0.4 MPa(60psi)	L	Life Indicator
15	Set at 0 to 1.5 MPa(200psi)	R	Flow direction : Right → Left
E	Non-relieving type	T	Tamper Resistant Kit
J2	Filter element - 20μm	U	Regulator (Top mounted)
J4	Filter element - 40μm	XC16	Copper-free

Note2) Refer to page 85 for Built-in Check valve, Tamper resistant kit.
 Note3) Separately packed, Not assembled.
 ※ If ordering more than one option, indicate symbols numerically then alphabetically Ex) 2EK
 ※ Over Max. pressure value can be set.

Construction

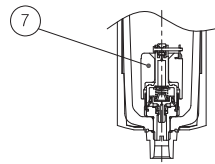
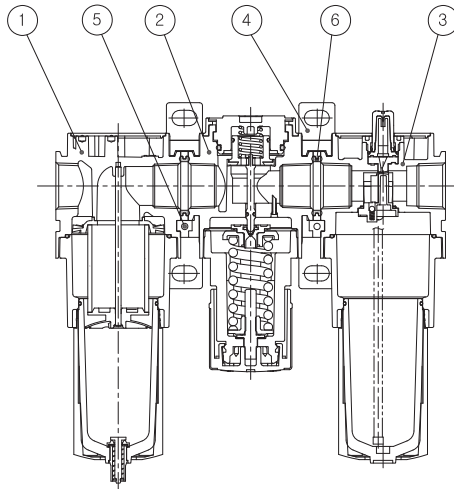

Auto-Drain Type

Main Parts / Parts List

No.	Description	Material	Remarks
①	Filter ass'y	-	
②	Regulator ass'y	-	
③	Lubricator ass'y	-	
④	Bracket ass'y	Aluminum	
⑤	Connecting screw	Carbon steel	

Replacement Parts / Parts List

No.	Description	Material	Part No.
⑥	Spacer O-ring	NBR	PC5-04-001-01
⑦	Auto-drain ass'y	-	TAF3000-04A-6008

Dimensions

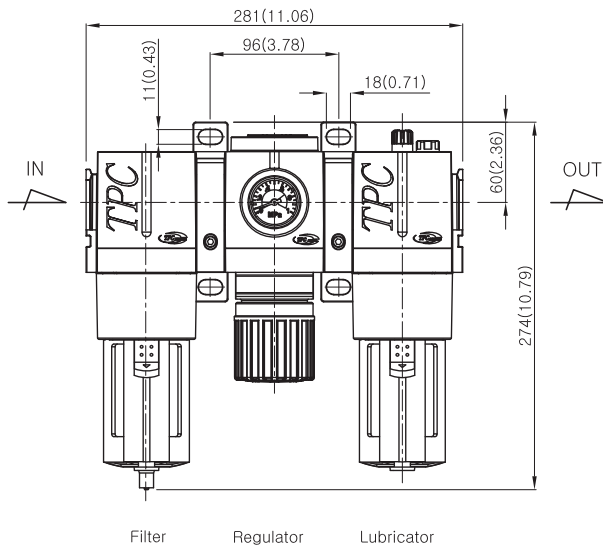

Filter Regulator Lubricator

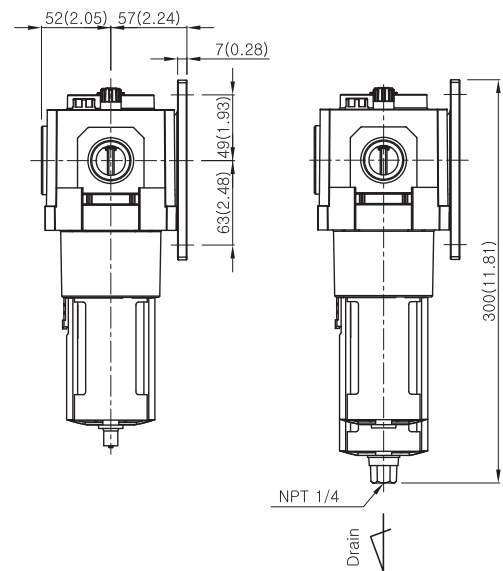

Auto-Drain Type

PC5 Series

Combinations 3/4" and 1"

PC5A Dimensions

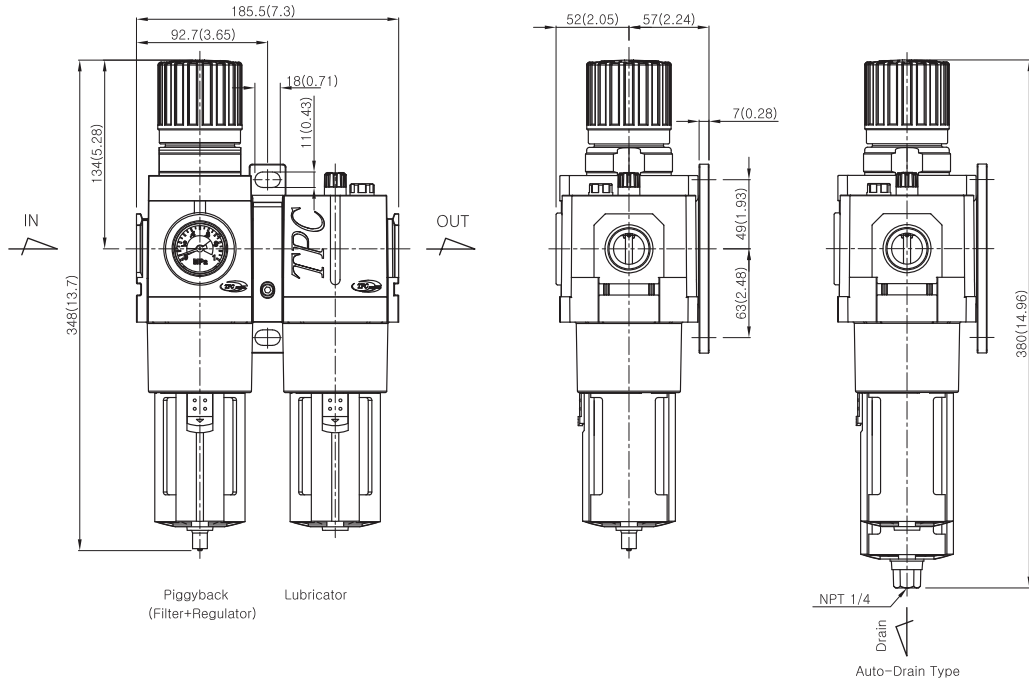

PC5B Dimensions

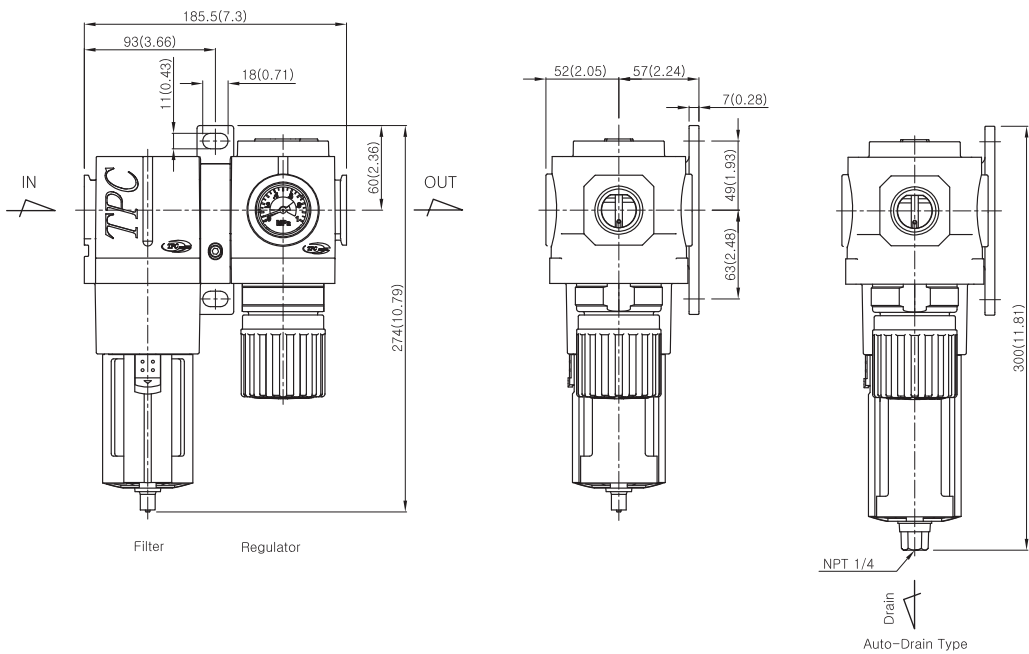

■ **PC5 Series Flow Characteristics**

▶ **3/4" PC5**

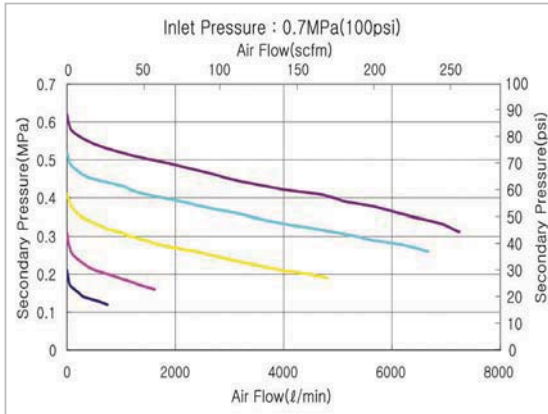

▶ **1" PC5**

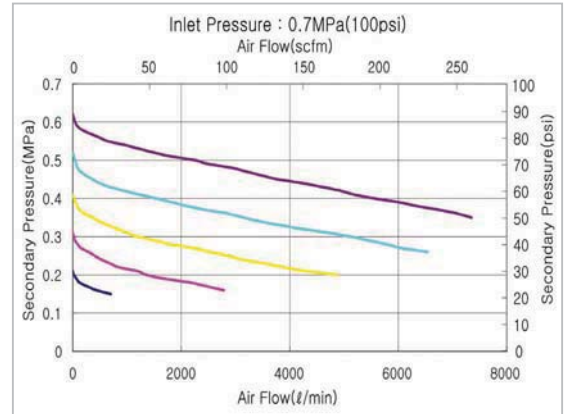

▶ **3/4" PC5A**

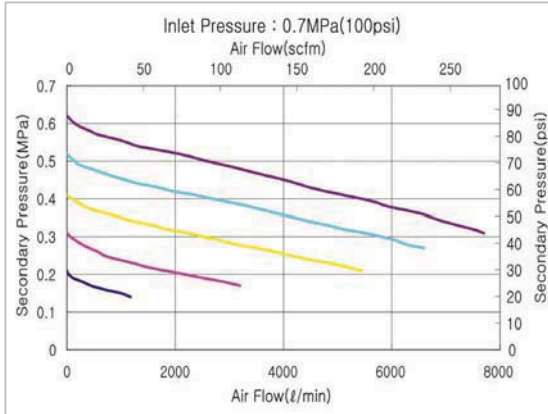

▶ **1" PC5A**

