

OPERATING INSTRUCTIONS

Installation of Seals:

- For seal install or replacement loosen set screw on side of housing.

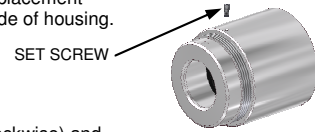

- Unscrew (counterclockwise) and remove seal casing. NOTE: A spanner wrench hole is provided for breaking the seal casing loose if required.

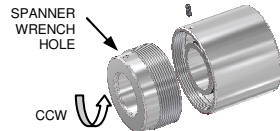

- Seal sets contain elastomer seals and backup washers per Chart 1. For complete listing of seal set size ranges see catalog.

- Verify that seals and washers are the same size.

- Assemble seal set into seal casing. See Chart 1.

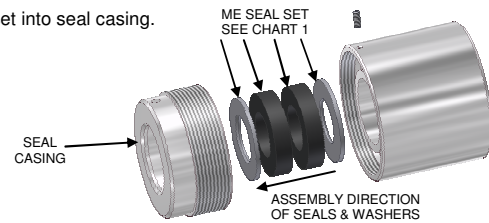

- Reassemble and tighten seal casing w/seal set to housing.

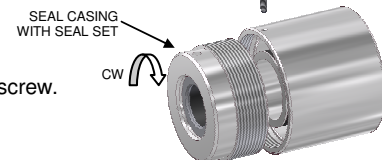

- Retighten set screw.

*Seal Set Parts Required CHART 1

Connector	Number of Seals	Number of Washers
ME01, ME01M	1	2
ME1, ME1M	1	2
ME2, ME2M	2	2
ME3, ME4, ME3M, ME4M	3	2
ME5, ME6, ME5M, ME6M	3	2

- Use of less than the listed number of seals (for less insertion depth) requires a spacer. See **Fastest** catalog. Seal Installation Instructions included with seal sets.

- WARNING:** Seals and washers must have the same size outside and inside diameters. Use of the incorrect size seals or washers will result in loss of seal ability.

Attachment of Pilot Pressure and Test Media Supply Line: ME MODEL CONNECTOR

- Attach pilot pressure line to pilot port "E" from Diagram 2.

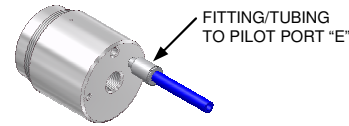

- A pneumatic regulated source is required to maximize seal life and assure optimum seal ability for the application. The pilot pressure should be minimized to maintain sealing on the test piece without excessive compression of the seal.

- Attach test media line to test port "D" from Diagram 2.

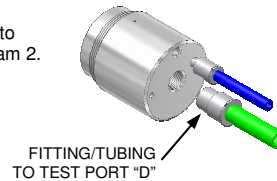

- Provide a means whereby test pressure will not be introduced until the pilot pressure required to seal is reached. The means should also provide quick exhaust of test pressure in the event pilot pressure falls below the minimum required to seal.

Mounting of Connector:

The ME Connector must be SECURED to the test piece by a mechanical device before proceeding.

- The test connector must be secured with a mechanical or other device to assure the connector is not uncoupled from the test piece. The test itself will provide an uncoupling force. The securing or holding device may be a fixture, clamp, cylinder or other appropriate means that prevents ejection of the test piece from the connector.

Uncoupling force example:

If the test piece has a 1/2" O.D. and is tested at 400 psi maximum. The uncoupling force = $\text{area}(\pi r^2) \times \text{pressure} = \pi \times .25^2 \times 400 = 79 \text{ lbs.}$

- Secured device should be designed to withstand this force and include an adequate margin for safety.
- Do not activate the connector without an adequate and safe securing mechanism.
- Mount the **Fastest** ME connector to the fixture or appropriate device using either threaded mounting holes on the rear of the connector body, ("G" Diagram 2), or appropriate adapter.

ME Connector Dimensions:

DIAGRAM 2

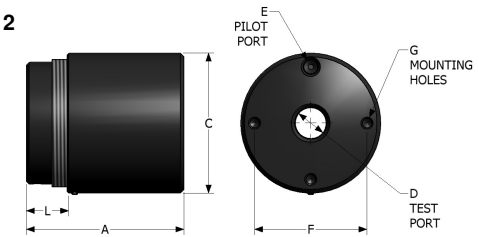

Maximum test pressure: Vacuum to 500 psi
Flow capability: Limited by "D" below

CHART 2

FE	A	C	D	E	F	G*	L**
ME01	2.05	1.49	1/8 NPTF	10-32 UNF	1.10	10-32 UNF	.58
ME01M			1/8 BSPP	M5x.8		M5x.8	
ME1	2.72	2.22	1/4 NPTF	1/8 NPTF	1.62	1/4-28 UNF	1.06
ME1M			1/4 BSPP	1/8 BSPP		M6x1	
ME2	3.50	3.11	1/2 NPTF	1/8 NPTF	2.50	1/4-28 UNF	1.06
ME2M			1/2 BSPP	1/8 BSPP		M6x1	
ME3	4.48	4.23	1 NPTF	1/8 NPTF	3.25	1/4-28 UNF	1.64
ME3M			1 BSPP	1/8 BSPP		M6x1	
ME4	4.60	5.48	1-1/2 NPTF	1/8 NPTF	4.25	1/4-28 UNF	1.64
ME4M			1-1/2 BSPP	1/8 BSPP		M6x1	
ME5	4.60	6.98	2 NPTF	1/8 NPTF	5.50	3/8-24 UNF	1.64
ME5M			2 BSPP	1/8 BSPP		M11x1.5	
ME6	4.97	7.48	2-1/2 NPTF	1/8 NPTF	6.12	3/8-24 UNF	1.64
ME6M			2-1/2 BSPP	1/8 BSPP		M11x1.5	

* ME4, ME4M, ME5, ME5M, ME6, ME6M have 3 mounting holes.

**L = Minimum insertion length of test piece.

Material Specifications

Body, Housing, Piston:

Aluminum

Main Seal Washers:

Steel QPQ treated or Stainless Steel

Main Seal:

FDA approved Neoprene

O-Rings:

FDA approved Viton

Other materials available on request.

NOTE: All specifications subject to change without notice.

OPERATING INSTRUCTIONS



Connector Operation:

- Insert test piece into the end of the connector and secure.**
Make sure the test piece is inserted to the required minimum insertion length. This will assure proper location relative to the seals. Make sure the connector and test piece are secure.
 - Apply pilot pressure to seal against the part.**
Generally, a 60 to 90 psi pneumatic pilot pressure source is required. Additional pilot pressure may be required for contoured surfaces (i.e., threads etc...). See FasTest catalog for Pilot Pressure Booster.
- CAUTION: Do not activate PILOT or TEST PRESSURE without test piece in place.**
- With pilot activated, introduce gas or liquid through the FasTest ME connector until desired testing, filling or flushing is complete.**
Provide a means whereby test pressure will not be introduced until the pilot pressure required to seal is reached. The means should also provide quick exhaust of test pressure in the event pilot pressure falls below the minimum required to seal.
 - Perform testing operation.**
 - Relieve test pressure.**
 - Relieve pilot pressure.**
 - Remove test piece.**

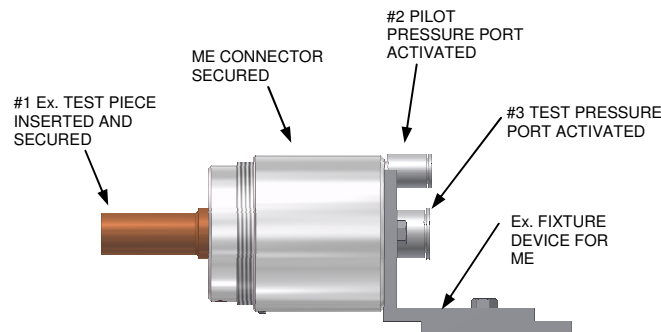
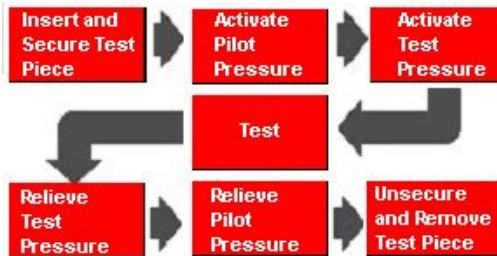

Connector Maintenance:

- A daily, weekly and periodic inspection of the connector by competent person is recommended.
- Lubricate connector on regular intervals. Petroleum jelly is recommended but care should be taken to verify the lubricant is compatible with the application.
- User must establish a regular interval for maintenance as determined by the user media and operational environment.
- Inspection should include damage to the body missing or loose components, leak tightness, ease of operation, sufficient lubrication, wear, dirt accumulation and damage.
- Use only original **FasTest** spare parts that are designed for the application and are subject to strict quality control. See warranty.

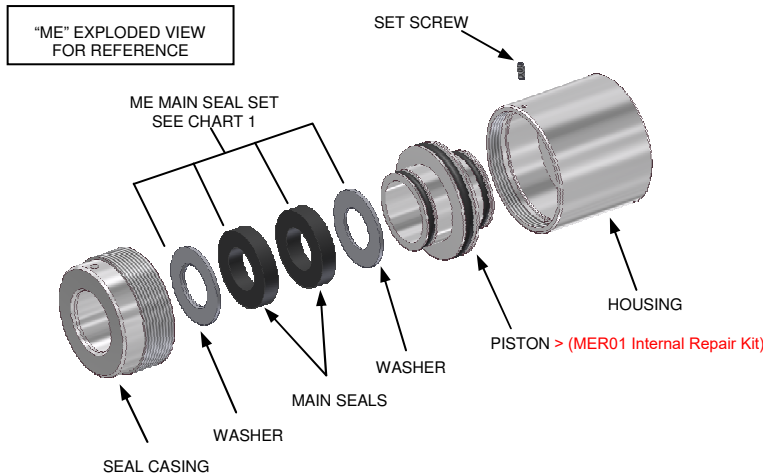

FasTest, Inc. Product Warranty

FasTest, Inc. warrants its products against defects of workmanship and/or material for ~~42 months~~ from the date of the sale by FasTest, Inc. This warranty is void if the product is misused, tampered with or used in a manner that is not in accordance with FasTest, Inc. recommendations and/or instructions. FasTest, Inc. is not liable for consequential or other damages including, but not limited to, loss, damage, personal injury, or any other expense directly or indirectly arising from the use of or inability to use its products either separately or in combination with other products. ALL OTHER WARRANTIES EXPRESSED OR IMPLIED, WHETHER ORAL OR WRITTEN, INCLUDING BUT NOT LIMITED TO WARRANTIES OR MERCHANTABILITY OR FITNESS FOR A PARTICULAR PURPOSE ARE EXPRESSLY EXCLUDED. Remedy under this warranty is limited to replacement of the product or an account credit in the amount of the original selling price, at the option on FasTest, Inc. All allegedly defective products must be returned prepaid transportation to FasTest, Inc. along with information describing the products performance, unless disposition in the field is authorized in writing by FasTest, Inc.

ME and MExM (Metric Termination) External Pneumatic Operated Connector.

DESCRIPTION: ME Connectors Seal on the Outside Diameter of Tubes and Threads.

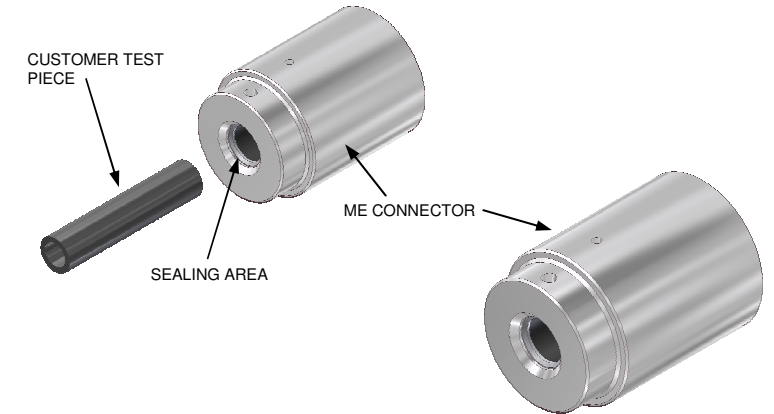

Please thoroughly read and understand each of the following four steps before operating the connector. The use of pressurized media for sealing, testing and filling requires a thorough understanding of the **FasTest** ME Installation and Operating Instructions.

- Installation of Seals**
- Attachment of Pilot Pressure and Test Media Supply Lines**
- Mounting Dimensions of Connector**
- Connector Operations Instructions.**

- The connector is designed to mate with a specific application. Verify the application prior to the introduction of pressure or processing.
- Use only in a safe environment.
- Connectors are NOT designed for permanent connections and are for temporary connections only.
- Maximum rated test pressure for standard ME models is 500 psi. DO NOT EXCEED pressure rating as marked on connector or corresponding literature. Consult your **FasTest** representative with other requirements.

FasTest ME Pneumatic Operated Connectors are designed for use in SECURED CONDITIONS ONLY.

Note: "M" designates metric customer interface. See Chart 2, column "G" for thread designations.