

OPERATING INSTRUCTIONS



Operating Instructions:

CONNECTING ACTION:

1. Insert connector into test piece. Make sure test piece is inserted to the required minimum insertion length. This will assure proper location relative to the seals.

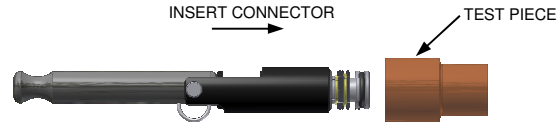

2. Rotate lever to the 90-degree position for grip and seal action. After connecting, always tug on the connector to assure proper engagement and gripping of the collet before introduction of pressurized test media.

Note: Lever is designed to rotate down when connector test port is on top.

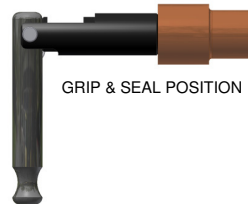

3. Introduce test media through test port.

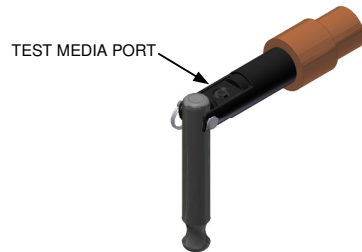

DISCONNECTING ACTION:

1. Vent test media pressure.
2. Rotate lever to in-line position.
3. Remove connector.

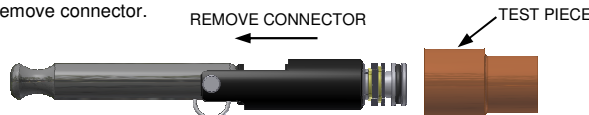

Note: Connector should be pulled straight back. If connector catches, push forward, and pull back. Do not attempt to force out a connector that is catching. This will cause it to jam in the test piece port.

Dimensional Information:

All DIMENSIONS APPLY TO BOTH SIZES EXCEPT "L" (Minimum insertion length of test piece for standard application).

LEVER ACTION *NuLaws*

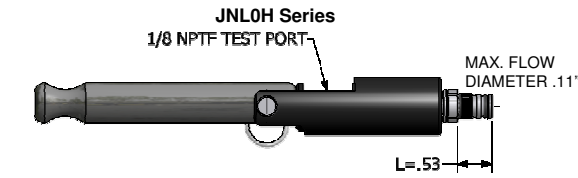

Lever in-line for connector insertion and disconnect

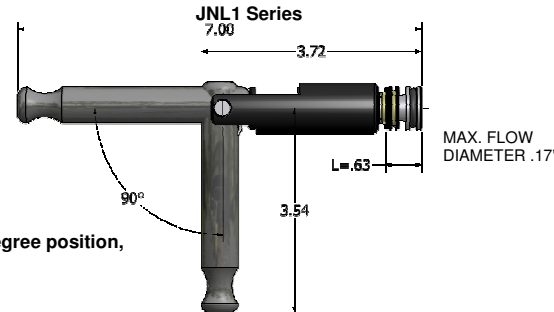

Lever at 90-degree position, grip and seal.

Collet and Seal Installation for *NuLaws* JNL Connector:

ASSEMBLY OF COLLET AND SEAL SET:

1. Set connector shaft (A) on table so that the threaded end is pointed upward. Place main seal (B) onto shaft as shown.
2. Install sleeve ramp (C) onto shaft so that smooth flat area is against main seal.
3. Place small C-Ring (D) into groove shown. Most easily installed from side. Sleeve ramp may need to be squeezed close to flat end of shaft to expose c-ring groove.

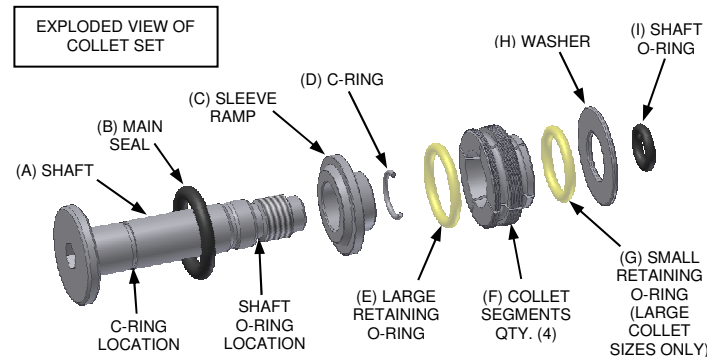

4. Assemble the collet segments (F) and retaining o-ring(s) (E) & (G). Arrange the four pieces of collet (F) into a circle with the raised area facing upward. Place the retaining o-ring(s) into the groove(s) on the raised area.

ASSEMBLY VIEW OF COLLET SET

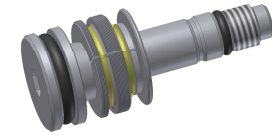

5. Install complete collet and retaining o-ring assembly onto shaft (A) as shown in diagram. Note that the I.D. of the collet assembly is tapered. Larger end of this tapered I.D. goes on the shaft (A) first.
6. Place washer (H) on shaft (A).
7. Place shaft o-ring (I) onto shaft (A) and into groove immediately in front of thread.
8. The shaft assembly is now ready to attach to the connector body. Apply a drop of Loctite® to the threads to avoid loosening during use.

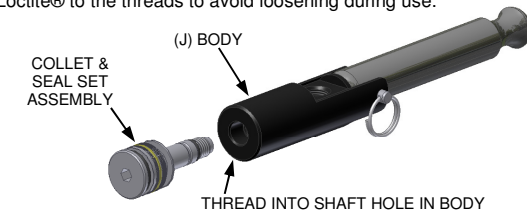

9. Holding body (J) with shaft hole pointed downward, insert threaded end of shaft (A) into hole in body (J). Using a hex wrench in hex hole at front of shaft, tighten shaft into body until snug. Collet set should be threaded in so that edge of collet (F) overlaps edge of sleeve ramp (C) by approximately .02".
10. Final adjustment requires a Ø.105 gage pin for JNL0(H) connectors and a Ø.130 gage pin for JNL1 connectors.
11. Slide required gage pin in the gap between collet and sleeve, collet set is properly adjusted if the gage pin slips in with little (.005" or less) clearance. If pin requires any force at all to slip in, the collet set should be re-adjusted.

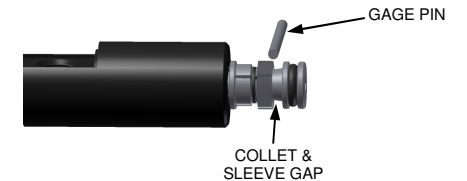

12. Rotate the lever to actuate connector. Visually verify that the connectors gripping and sealing action is correct before introduction of pressurized test media.

CAUTION: Keep fingers away from collet assembly. Pinching can occur.

OPERATING INSTRUCTIONS

Replacement of Main Seal:

1. Place lever in the in-line position so that seal/collet assembly is in the relaxed position. Using a pointed repair tool to get behind the main seal (B) and roll this seal over the front of shaft.



2. Verify correct size and material of replacement main seal.
3. Install the replacement main seal (B) by rolling it over the front end of shaft into the space between the shaft and sleeve ramp (C). Be sure seal is seated in groove.
4. Rotate lever to actuate connector. Visually verify that the connector gripping and sealing action is correct.

CAUTION: Attach assembled *NuJaws* connector to a test piece and tug on the connector to assure proper engagement and gripping of collet before introduction of pressurized test media.

Safety Warnings – General Guidelines:

1. If instructions are not completely understood by operator or components are missing, contact **FasTest** before attempting use of the connector.
2. All operating parameters should be considered when connector selection is made. Parameters include, but are not limited to: dimensional tolerance, hardness and surface finish of test piece, pressure or vacuum requirements of application, fluid compatibility, temperature, environment and mechanical load or vibration affecting the connector.
3. **FasTest** JNL Connectors must only be used with test pieces of a specific size as indicated by the part number. Improper use could cause separation of the connector from the test piece resulting in physical harm or damage. The connector part number and maximum pressure rating is marked clearly on the label.
4. **FasTest** JNL Connectors are to be used only on materials that meet the following specifications: The test piece must have a surface finish greater than 16rms and a hardness of no more than 95Rb, to grip and seal at the rated pressure. A surface finish of 8rms may be acceptable if the test piece has a hardness greater than 40Rb. If the application is out of this range, or there is a question concerning this requirement, contact **FasTest**.
5. **CAUTION REMINDER: Keep fingers or other objects away from gripping collets when actuating connector. Pinching or crushing can occur.**
6. **FasTest JNL Connectors are not internally valved, and will not prevent loss of media when disconnected. Do not attempt to disconnect unless safe conditions are met.**

Connector Maintenance:

- A daily, weekly, and periodic inspection of the connector by competent person is recommended. User must establish a regular interval for maintenance as determined by the user media and operational environment.
- Lubricate connector on regular intervals. Using WD-40 or a like product is recommended but care should be taken to verify the lubricant is compatible with the application. Lightly spray the collet segments of the connector.
- Inspection should include visual checks of the collet sealing area, housing, missing or loose components, leak tightness, ease of operation, sufficient lubrication, wear, dirt accumulation and damage.
- Use only original **FasTest** spare parts that are designed for the application and are subject to strict quality control. See warranty.

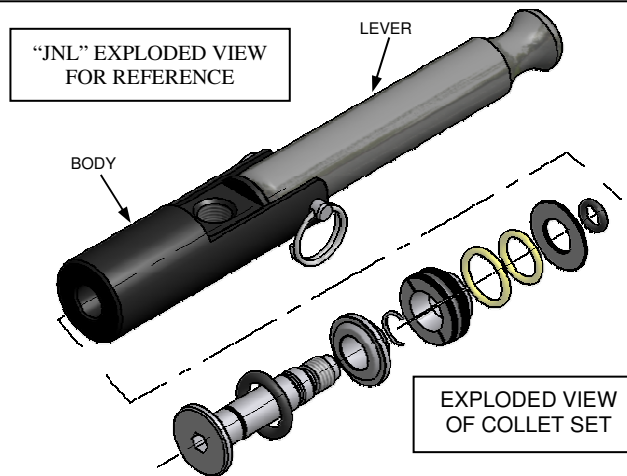

FasTest, Inc. Product Warranty

FasTest, Inc. warrants its products against defects of workmanship and/or material for 12 months from the date of the sale by FasTest, Inc. This warranty is void if the product is misused, tampered with, or used in a manner that is not in accordance with FasTest, Inc. recommendations and/or instructions. FasTest, Inc. is not liable for consequential or other damages including, but not limited to, loss, damage, personal injury, or any other expense directly or indirectly arising from the use of or inability to use its products either separately or in combination with other products. ALL OTHER WARRANTIES EXPRESSED OR IMPLIED, WHETHER ORAL OR WRITTEN, INCLUDING BUT NOT LIMITED TO WARRANTIES OF MERCHANTABILITY OR FITNESS FOR A PARTICULAR PURPOSE ARE EXPRESSLY EXCLUDED.

Remedy under this warranty is limited to replacement of the product or an account credit in the amount of the original selling price, at the option of FasTest, Inc. All allegedly defective products must be returned prepaid transportation to FasTest, Inc. along with information describing the products performance, unless disposition in the field is authorized in writing by FasTest, Inc.

NuJaws JNL Lever Action Grip and Seal Connectors.

DESCRIPTION: Operating Instructions for JNL0(H) & JNL1. Instant Internal Connections to 1,000 psi.



NuJaws JNL Connectors provide a reliable leak-tight connection that grips and seals in holes and ports. Simply place the JNL connector into a port, activate the mechanical gripping and sealing action, then introduce the test media. For vacuum to 1000 psi applications with air, gas, or liquid, **FasTest NuJaws** JNL Connectors provide secure, leak tight sealing for manual connections.

Please thoroughly read and understand each of the following four steps before operating the connector. The use of pressurized media for sealing, testing, and filling requires a thorough understanding of the **FasTest** JNL Installation and Operating Instructions.

1. **Operating Instructions**
2. **Dimensional Information**
3. **Collet and Seal Installations**
4. **Safety-General Guidelines**

- The connector is designed to mate with a specific application. Verify the application prior to the introduction of pressure or processing.
- Use only in a safe environment.
- Connectors are NOT designed for permanent connections and are for temporary connections only.
- Maximum rated test pressure for standard JNL models is 1000 psi. DO NOT EXCEED pressure rating as marked on connector or corresponding literature. Consult your **FasTest** representative with other requirements.