

Main Seal Replacement & Re-Build Instructions

Connector Maintenance:

- Establish a regular interval for maintenance as determined by user media and operational environment.
- Inspection should include visual checks of the sealing area, jaw wear, missing or loose components, leak tightness, ease of operation, sufficient lubrication, wear, dirt accumulation and damage.
- Establish a regular interval for lubrication. The media and environment will be determining factors in establishing this interval to prevent dryness and/or corrosion.
- Difficulty of operation after continual use indicates a need for lubrication or other maintenance.
- Use only original **FasTest** spare parts that are designed for the application and are subject to strict quality control. See warranty.

Safety Warnings – Guidelines:

- If instructions are not completely understood by operator or components are missing, contact **FasTest** before attempting use of the connector.
- Application Safety: All **FasTest** products have been designed with safety in mind; however, it is the responsibility of the user to design each process in such a way to avoid mishaps that can cause physical hazard or property loss. Secondary restraints such as safety chains, shields, cages or fixtures are all good choices depending on the application. **FasTest** can recommend or assist you in clarifying potential hazards of your application.
- **FasTest 70 Series Fuel Rail** connectors (part number FRV70XXXXX) are internally valved to prevent loss of media when disconnected. FasTest recommends that any connection or disconnection be made only when pressure is reduced to ambient.
- **FasTest 70 Series Fuel Rail** connectors (part number FR70XXXXX) are not internally valved and will not prevent loss of media when disconnected. Do not attempt to disconnect unless safe conditions are met.
- **FasTest 70 Series Fuel Rail** connectors must only be used with test pieces of a specific size as indicated by the part number. Improper use may separate the connector from the test piece resulting in physical harm or damage.

FasTest, Inc. Product Warranty

FasTest, Inc. warrants its products against defects of workmanship and/or material for 12 months from the date of the sale by FasTest, Inc. This warranty is void if the product is misused, tampered with or used in a manner that is not in accordance with FasTest, Inc. recommendations and/or instructions. FasTest, Inc. is not liable for consequential or other damages including, but not limited to, loss, damage, personal injury, or any other expense directly or indirectly arising from the use of or inability to use its products either separately or in combination with other products. ALL OTHER WARRANTIES EXPRESSED OR IMPLIED, WHETHER ORAL OR WRITTEN, INCLUDING BUT NOT LIMITED TO WARRANTIES OR MERCHANTABILITY OR FITNESS FOR A PARTICULAR PURPOSE ARE EXPRESSLY EXCLUDED.

Remedy under this warranty is limited to replacement of the product or an account credit in the amount of the original selling price, at the option on FasTest, Inc. All allegedly defective products must be returned prepaid transportation to FasTest, Inc. along with information describing the products performance, unless disposition in the field is authorized in writing by FasTest, Inc.

70 Series Fuel Rail Main Seal Replacement & Repair Kit Re-Build Instructions

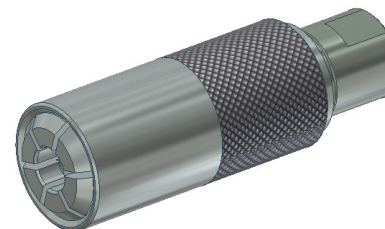

FasTest 70 SERIES FUEL RAIL connectors are designed to provide a safe, reliable leak-tight seal and connection when properly maintained and operated on SAE J2044 formed tubes.

Please thoroughly read and understand these repair instructions prior to disassembling the connector.

Tools required are a sharp pick, small flat screwdriver, 3/16" hex tool, and torque wrench for 35 in-lb.

- Main Seal Only Replacement
- Repair Kit/Re-Build Instructions
- Connector Maintenance
- Safety Warnings – Guidelines

Main Seal Replacement:

1. Slide sleeve back allowing jaws to open. With jaws open the main seal in piston is exposed enough to remove.

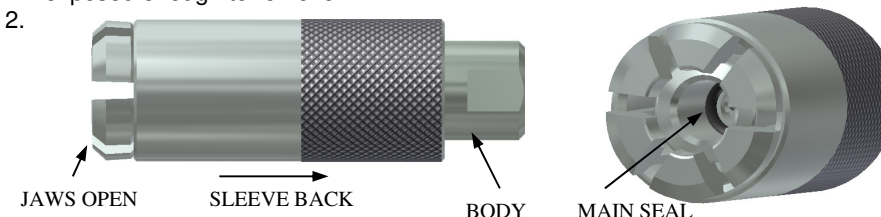

Main Seal Replacement & Re-Build Instructions



- Using sharp pick, carefully poke tool around outside diameter of main seal and pull out of piston.

NOTE - BE CAREFUL NOT TO DAMAGE PISTON!

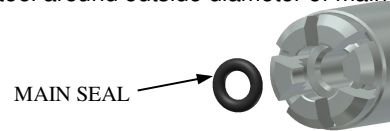

- Place a small amount of petroleum jelly (vaseline) on new seal.
- With sleeve still pulled back and jaws open install the new main seal. Using a pick, carefully push new seal into piston groove. Take care not to damage seal.

Repair Kit / Re-Build Instructions:

Dis-assembly

NOTE: ALL REPAIR KITS EXCEPT FOR THE 1/2" COME WITH BOTH THE WAVE STYLE AND COMPRESSION STYLE PISTON SPRING. ONLY USE THE WAVE SPRING IF YOU'VE REMOVED A WAVE SPRING FROM THE CONNECTOR THAT IS BEING RE-BUILT.

- Relieve pressure and remove fitting from termination port. Stand connector up on flat surface with jaws down as shown.
- Using small screwdriver, remove the retaining ring in body. Slide ring all the way off the body and discard.
- Remove stop ring and sleeve spring. Discard spring. Retain stop ring for reuse.



- Remove sleeve in the same direction as retaining ring and sleeve spring. As sleeve is removed hold jaws collapsed with other hand. This will keep the piston contained inside the jaws.

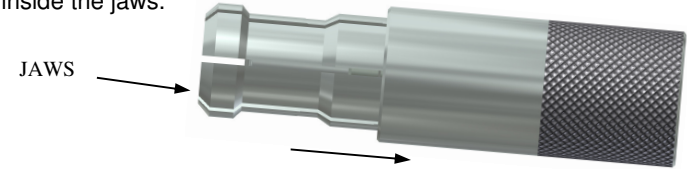

- With sleeve completely removed, carefully allow jaws to open far enough to let piston and wave/coil spring come forward and out of body. Discard spring.

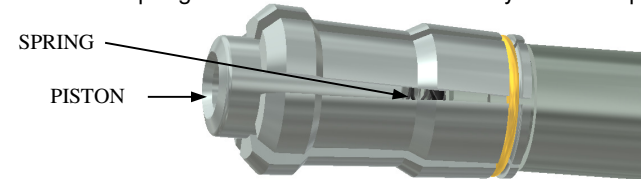

- Remove jaws and retaining o-ring, discard o-ring.

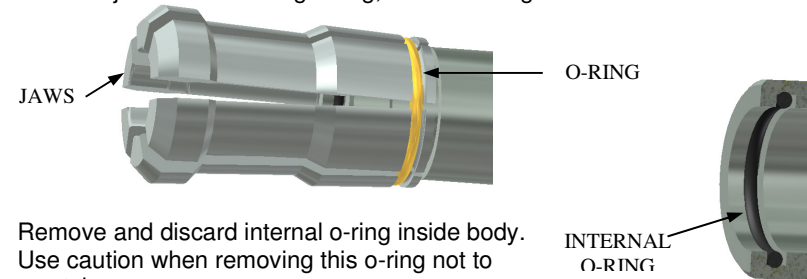

- Remove and discard internal o-ring inside body. Use caution when removing this o-ring not to scratch groove.
- Remove valve cartridge through termination port using a 3/16" hex tool and a wrench on flats of body. Discard valve cartridge.

Main Seal Replacement & Re-Build Instructions

Re-Assembly

1. Lube body o-ring with petroleum jelly and install into internal groove.

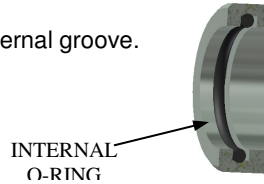

2. Place one jaw segment onto body then wrap new urethane o-ring around jaw groove and body. Install remaining jaw segments under urethane o-ring.

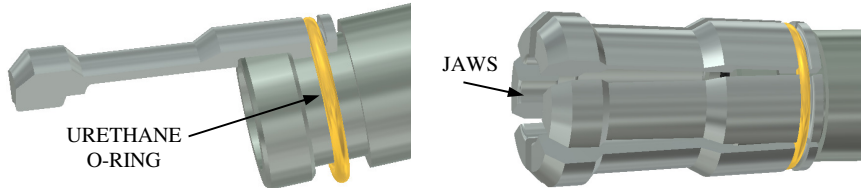

3. Install new spring into body and place piston onto spring. Refer to "Main Seal Replacement" to replace seal inside of piston.

4. Push piston down into body until jaws collapse and surround piston. You will feel resistance from spring and internal seal/o-ring in body.

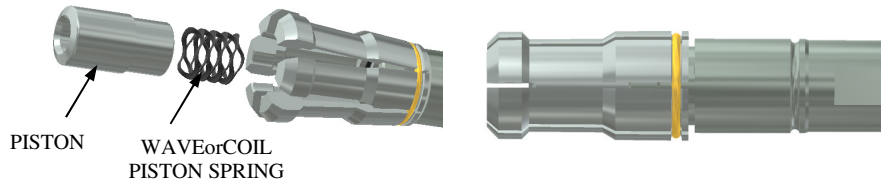

5. Hold jaws closed with one hand and load sleeve with the other hand.

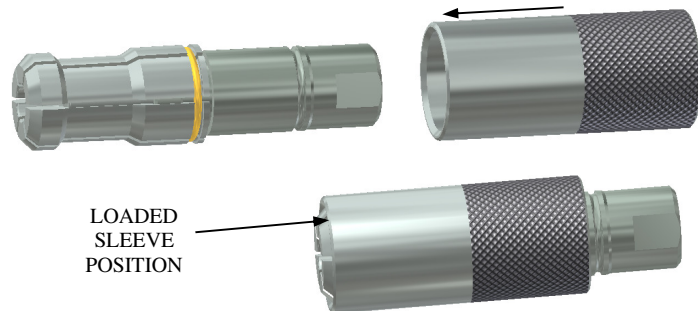

6. With sleeve loaded, stand connector up in vertical position and install new sleeve spring, stop, and new retaining ring. Using a pick or small flat screwdriver, push the retaining ring down body and into groove on body.

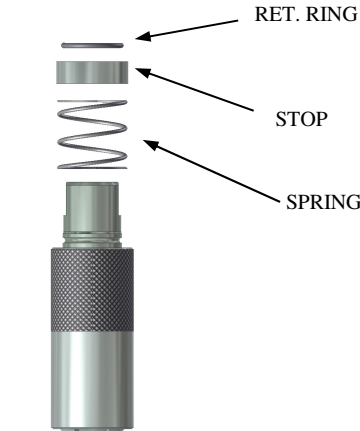

7. Test function before applying pressure to the rebuild connector.

