

REBUILD/REPAIR INSTRUCTIONS

Page 1 of 9



Connector Maintenance:

- A daily, weekly and periodic inspection of the connector by competent person is recommended. User must establish a regular interval for maintenance as determined by the user media and operational environment.
- Inspection should include visual checks of the sealing area, handle wear, missing or loose components, leak tightness, ease of operation, sufficient lubrication, wear, dirt accumulation and damage.
- Establish a regular interval for lubrication. The media and environment will be determining factors in establishing this interval to prevent dryness and/or corrosion.
- Difficulty of operation after continual use indicates a need for lubrication or other maintenance.
- Use only original **FasTest** spare parts that are designed for the application and are subject to strict quality control. See Warranty.

Safety Warnings – Guidelines:

- If instructions are not completely understood by operator or components are missing, contact **FasTest** before attempting use of the connector.
- Application Safety: All **FasTest** products have been designed with safety in mind, however, it is the responsibility of the products users to design each process in such a way to avoid mishaps that can cause physical hazard or property loss. Secondary restraints such as safety chains, shields, cages or fixtures are all good choices depending on the application. **FasTest** can recommend or assist you in clarifying potential hazards of your application.
- **FasTest 60/70** Connectors are not internally valved, and will not prevent loss of media when disconnected. Do not attempt to disconnect unless safe conditions are met.
- **FasTest 60/70** Connectors must only be used with test pieces of a specific size as indicated by the part number. Improper use could cause separation of the connector from the test piece resulting in physical harm or damage.

FasTest, Inc. Product Warranty

FasTest, Inc. warrants its products against defects of workmanship and/or material for 1 year from the date of the sale by FasTest, Inc. This warranty is void if the product is misused, tampered with or used in a manner that is not in accordance with FasTest, Inc. recommendations and/or instructions. FasTest, Inc. is not liable for consequential or other damages including, but not limited to, loss, damage, personal injury, or any other expense directly or indirectly arising from the use of or inability to use its products either separately or in combination with other products. ALL OTHER WARRANTIES EXPRESSED OR IMPLIED, WHETHER ORAL OR WRITTEN, INCLUDING BUT NOT LIMITED TO WARRANTIES OR MERCHANTABILITY OR FITNESS FOR A PARTICULAR PURPOSE ARE EXPRESSLY EXCLUDED.

Remedy under this warranty is limited to replacement of the product or an account credit in the amount of the original selling price, at the option on FasTest, Inc. All allegedly defective products must be returned prepaid transportation to FasTest, Inc. along with information describing the products performance, unless disposition in the field is authorized in writing by FasTest, Inc.

60/70 ICON™ Re-Build Instructions

Description: *60/70 Series Connectors to Grip and Seal Male threads and Males Features with ICON™ CV04.*

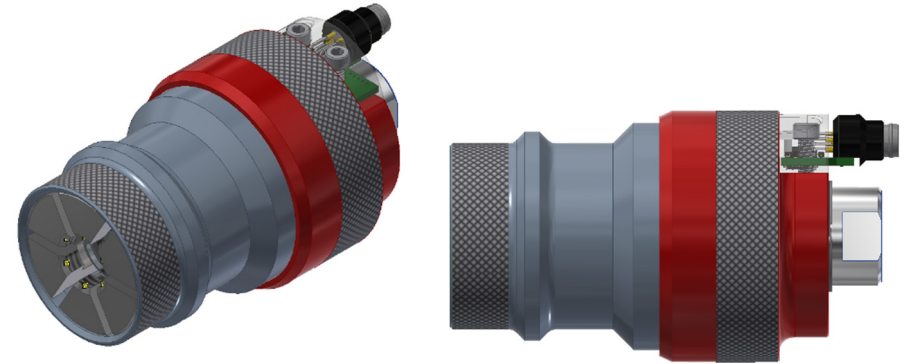

60/70 ICON™ Connectors provide a reliable leak-tight connection that grips and seals male threads and male features.

Please thoroughly read and understand these repair instructions prior to dis-assembling the connector.

Tools required are as follows:

Arbor press, hex wrench, sharp pic, small flat screw, Vaseline

Topics covered:

- Dis-assembly and Re-assembly Instructions
- Connector Maintenance
- Safety Warnings – Guidelines

REBUILD/REPAIR INSTRUCTIONS

Page 2 of 9



Dis-Assembly:

1. Dis-connect supply line from the termination port.
2. Remove screws and ICON module. Discard or save as needed.

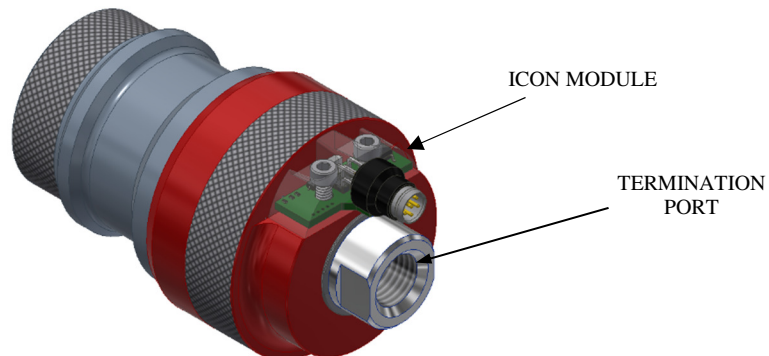

3. Remove spring and actuator from backside hole and discard.

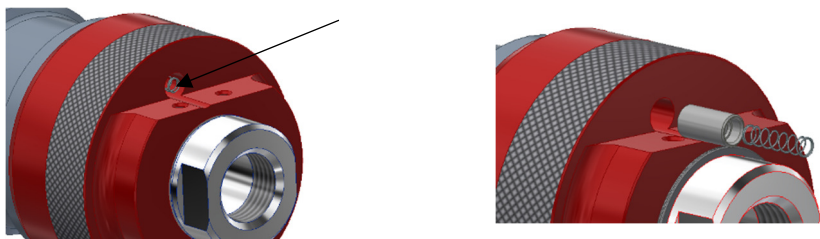

4. Remove retaining ring from groove in the body and discard.

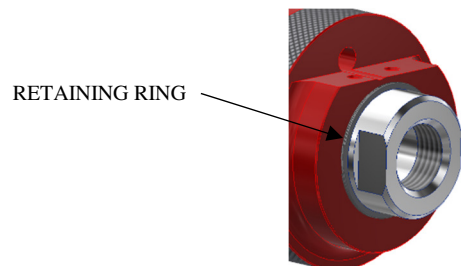

5. Push the piston in so the jaws collapse inside the sleeve.
6. Hold one hand around sleeve and jaw end of the connector and pull the sleeve assembly out of the red housing.

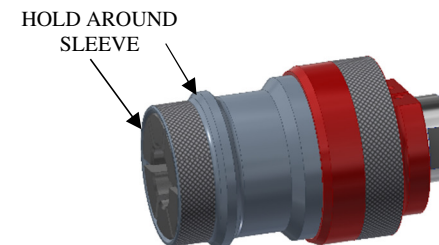

7. Housing removed from the sleeve assembly.

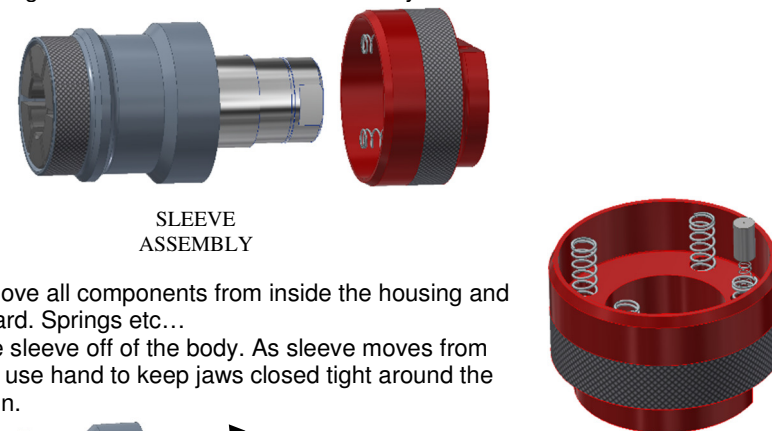

8. Remove all components from inside the housing and discard. Springs etc...
9. Slide sleeve off of the body. As sleeve moves from jaws use hand to keep jaws closed tight around the piston.

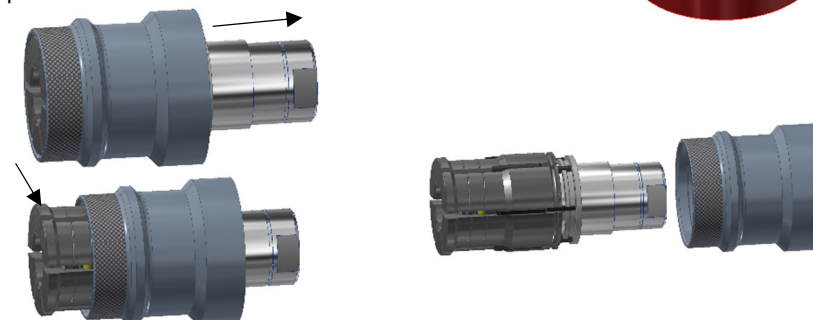

REBUILD/REPAIR INSTRUCTIONS

Page 3 of 9



10. Remove the jaw retaining o-ring.

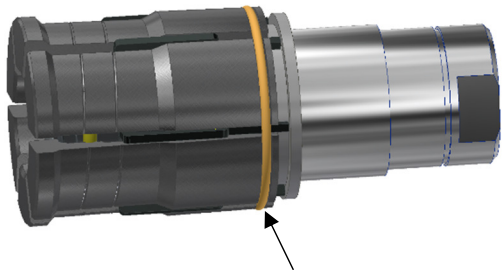

11. With that o-ring removed the jaws and jaw spacers can be separated from the body.

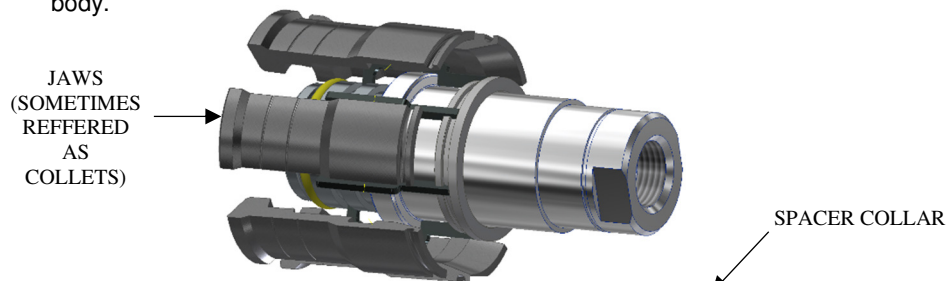

12. Remove the spacers.

13. Slide spacer collar off of body.

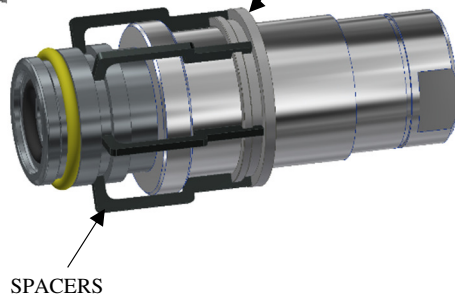

14. Remove piston and spring from body.

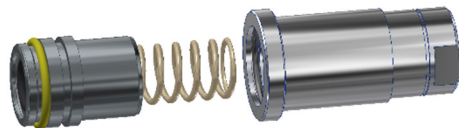

15. Discard piston spring.



16. Remove and discard external o-ring on piston. (NOTE: NOT ALL PISTONS HAVE THIS EXTERNAL O-RING.)

17. MAIN SEAL INSIDE PISTON DOES NOT COME WITH REPAIR KIT, MAIN SEAL BULK PACKS ARE SOLD SEPARATELY.

18. On select ICON connectors there might be an external o-ring on the bottom end of piston, this is to be removed and replaced.

EXTERNAL PISTON O-RING

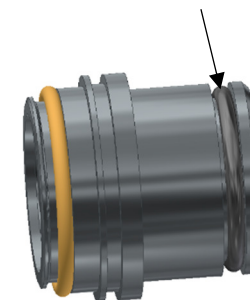
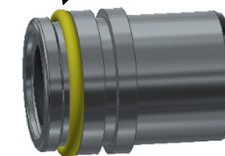

19. On applicable connectors remove the internal o-ring inside the body.

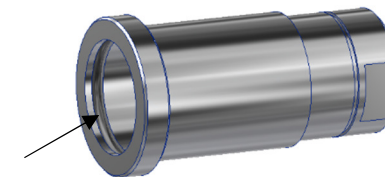

20. Clean and inspect all parts that will be re-used.

REBUILD/REPAIR INSTRUCTIONS

Page 4 of 9



Re-Assembly:

1. Install new springs, actuator/magnet and actuator spring into holes shown inside housing.

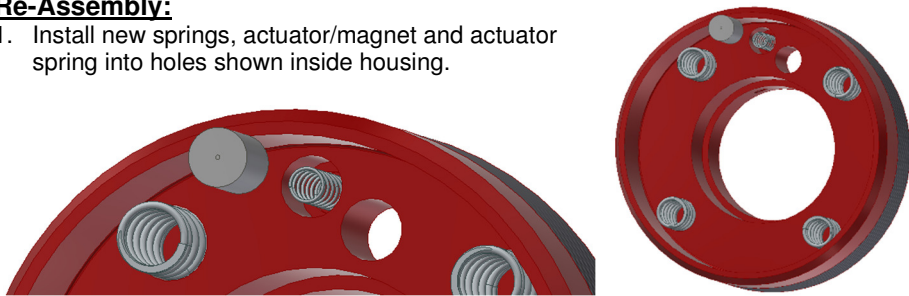

2. Open end of the actuator/magnet goes against the actuator spring. Set housing aside.
3. Install and lubricate new o-ring inside the body. Petroleum jelly.

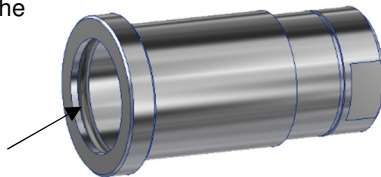

4. Load and lubricate new o-ring(s) onto the piston.

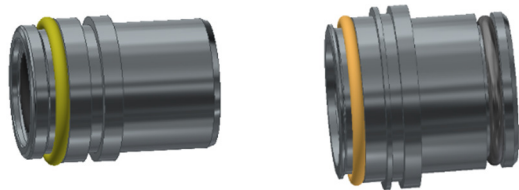

5. Place spacer collar onto body. Make sure small diameter of collar goes on first.

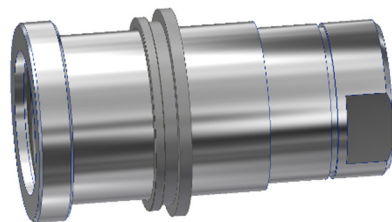

6. Next steps require the use of an arbor press and a tool we shall call "sleeve tool".
 - Sleeve tool requirements.
 - i. Tool must fit inside the sleeve.
 - ii. Tool must be as long or slightly longer than sleeve.
 - iii. Body needs to drop inside tool as shown.

7.

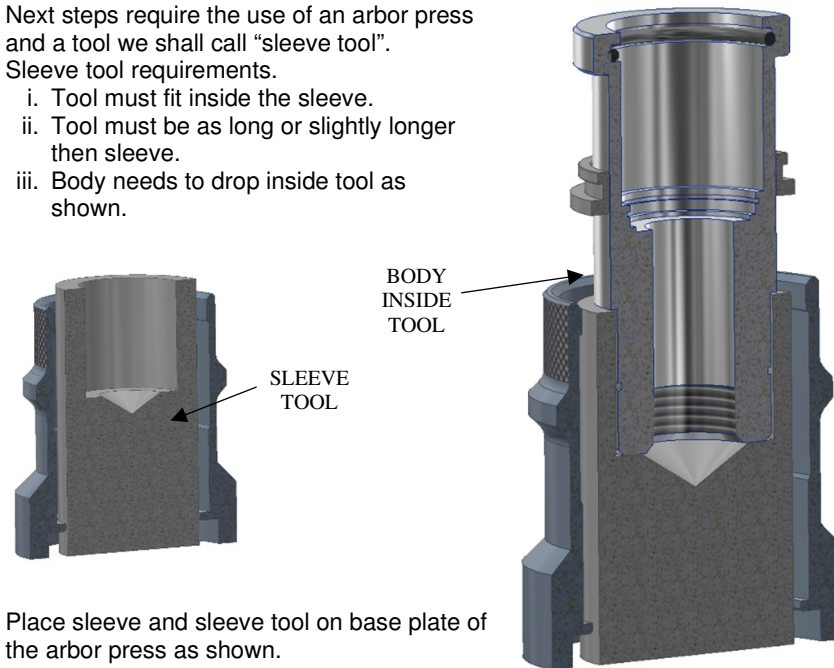

8. Place sleeve and sleeve tool on base plate of the arbor press as shown.
9. Place body inside tool.
10. Place collet/jaw retaining o-ring over body.
11. This o-ring retains the collet/jaw segments in place around the body. No lube required on this o-ring.

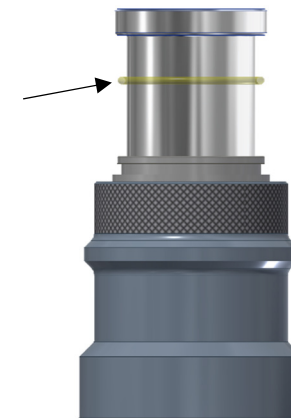

REBUILD/REPAIR INSTRUCTIONS

Page 5 of 9



12. Install collets and or jaws onto body.

- **Type 60 Connectors with threaded collets** – *The outside of the collets will have a spiral groove denoting the installation sequence of the collets. Line up the collets so that the spiral groove forms a constant line along/around the circumference of the collets when they are assembled onto body. Install each collet segment one by one by inserting them underneath the collet o-ring. Make sure each collet segment is seated properly onto the body.*
- **Type 70 Connectors with non-threaded jaws** – *No specific sequences are required to align and install jaw segments. Install them onto the body one by one by inserting them underneath the jaw o-ring. Make sure each jaw segment is seated properly onto the body.*
- **THE USE OF AN ADDITIONAL O-RING TO HOLD THE COLLETS/JAWS IN PLACE WILL HELP AS EACH SEGMENT IS LOADED. THEN REMOVE THE O-RING FROM CONNECTOR.**

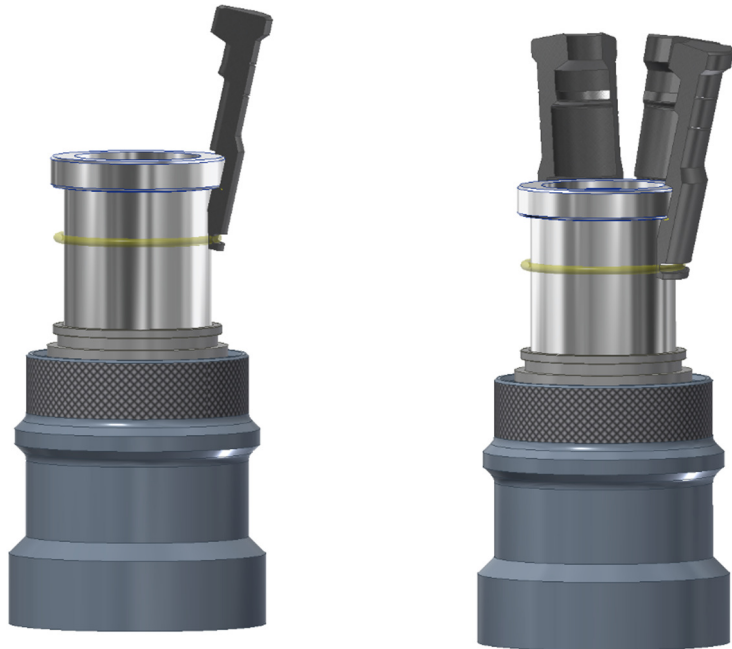

13. Allow collets/jaws to open enough to install spring and piston into body.

14. **IN SOME CASES THE SPRING AND PISTON MIGHT NEED TO BE INSTALLED AND PRESSED DOWN BEFORE COLLETS/JAWS ARE INSTALLED AROUND THE BODY. MAKE SURE NOT TO DAMAGE MAIN SEAL INSIDE PISTON.**



← SPIRAL GROOVES

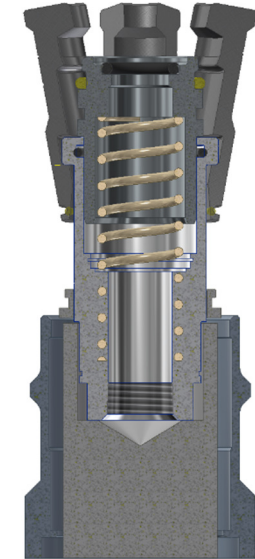

REBUILD/REPAIR INSTRUCTIONS

Page 6 of 9



15. Using arbor press and non-marring pin against main seal, press piston into body until collets/jaws can collapse around the piston. Lock arbor in place.
16. Next step is to install the collet/jaw spacer segments in between each collet/jaw segment.

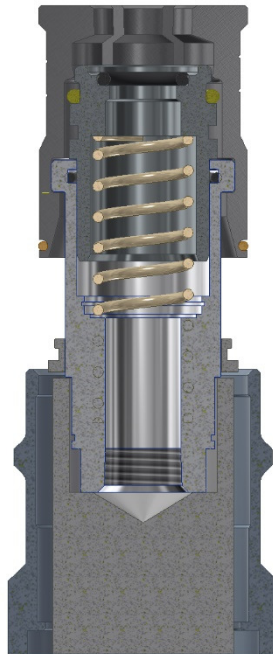
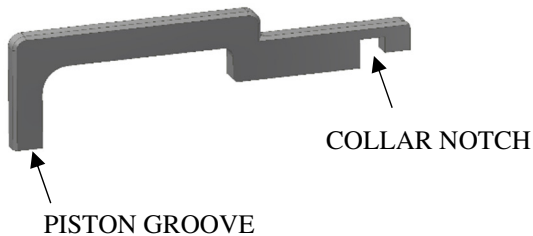

19. Slip the spacer under the collet o-ring. SPACER SHOWN IN RED FOR CLARITY OF POSITION.

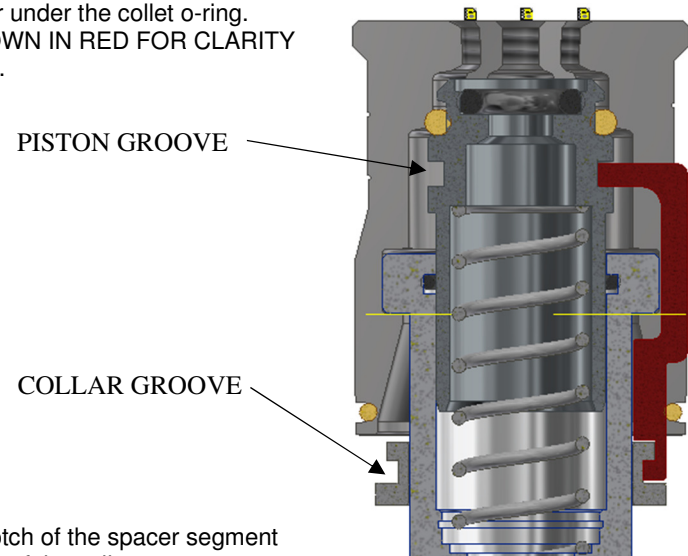

17. Raise the spacer collar up towards the bottom end of collet/jaw segments.
18. Insert spacer segments one at a time.

20. Place collar notch of the spacer segment into the groove of the collar.
21. The other end of the spacer goes into the groove on the piston.
22. Install all six segments.
23. Collet/jaw o-ring helps to retain the spacer segments until sleeve is slid up and into place.

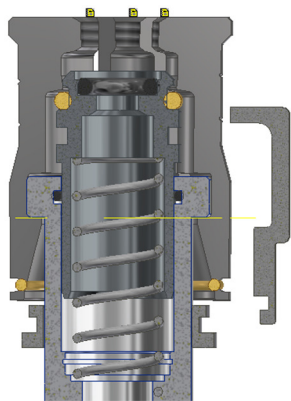

REBUILD/REPAIR INSTRUCTIONS

Page 7 of 9



24. Holding collets/jaws around the piston, slide the sleeve up. Sleeve will stop against the bottom ends of collet/jaw segments.

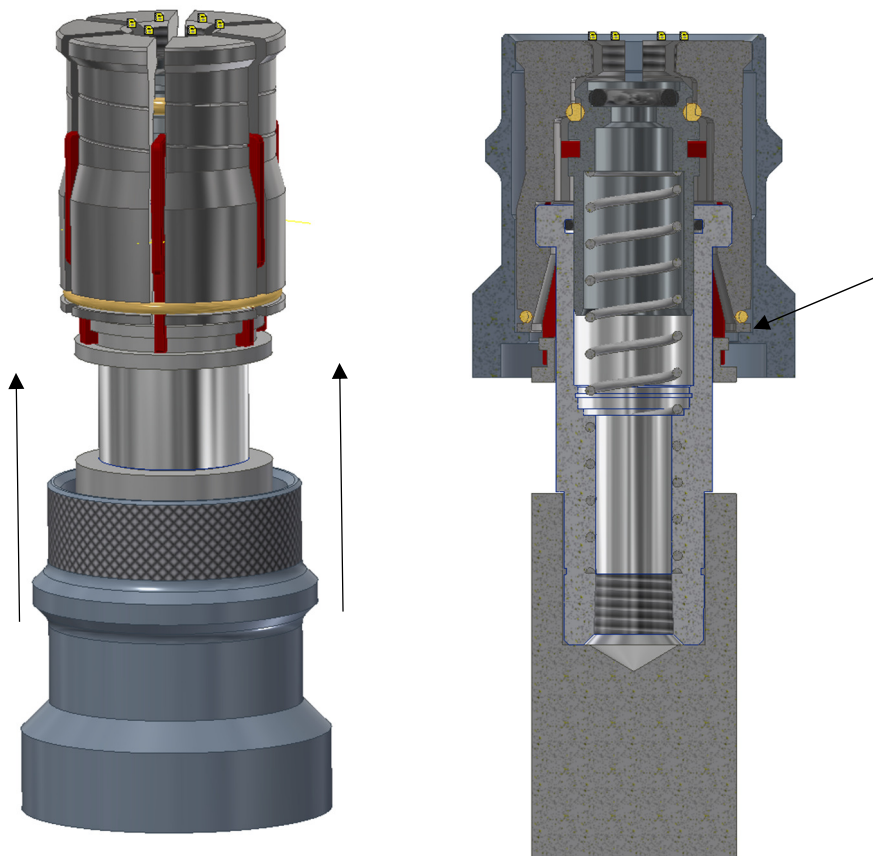

25. Wrap one hand around the sleeve and hold collets/jaws inside sleeve, unlock and raise the arbor press up and out of the piston.
 26. Remove this sleeve sub-assembly from the sleeve tool.
 27. Keep collets/jaws inside sleeve.

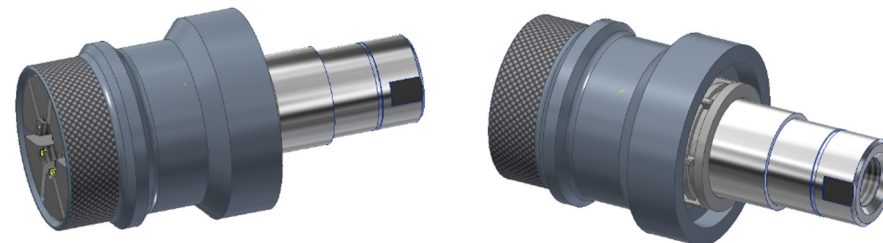

SLEEVE SUB-ASSEMBLY

28. Carefully lower/slide the entire sleeve sub-assembly into the housing.
 29. Make sure the magnet actuator is going to get pushed into the hole as sleeve assembly is lowered into housing.
 30. Push these assemblies together until the groove in body is exposed below the housing.

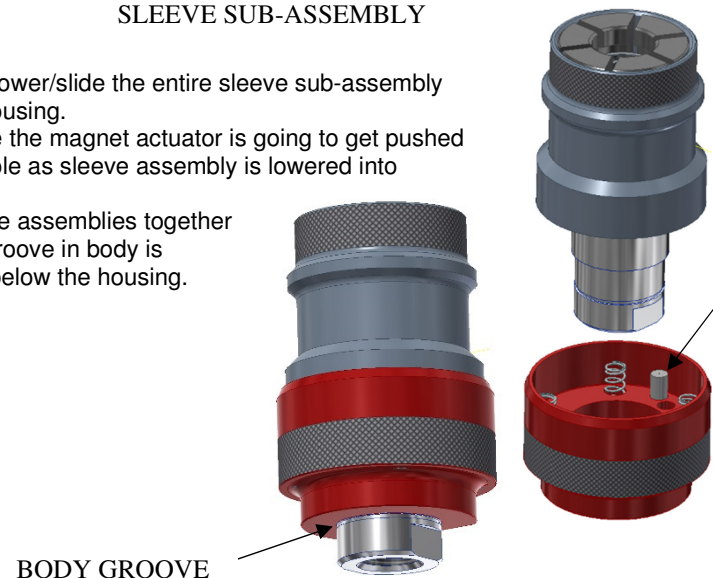

BODY GROOVE

REBUILD/REPAIR INSTRUCTIONS

Page 8 of 9



31. Rotate this assembly so sleeve end is on flat surface.
32. Make sure collets/jaws stay inside the sleeve.
33. Install retaining ring into groove on body.

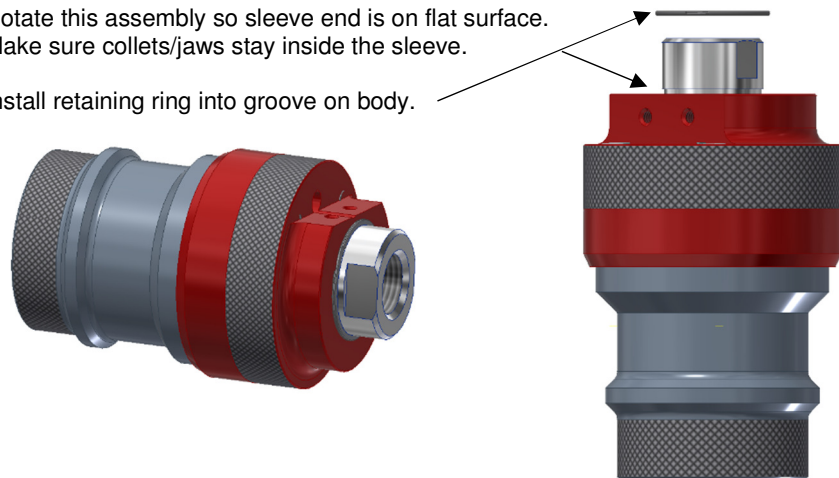

35. Slide the ICON module along the flat on housing.
36. ICON module will be used to compress and contain the magnet spring into place.
37. Install the screws through module and into the housing.

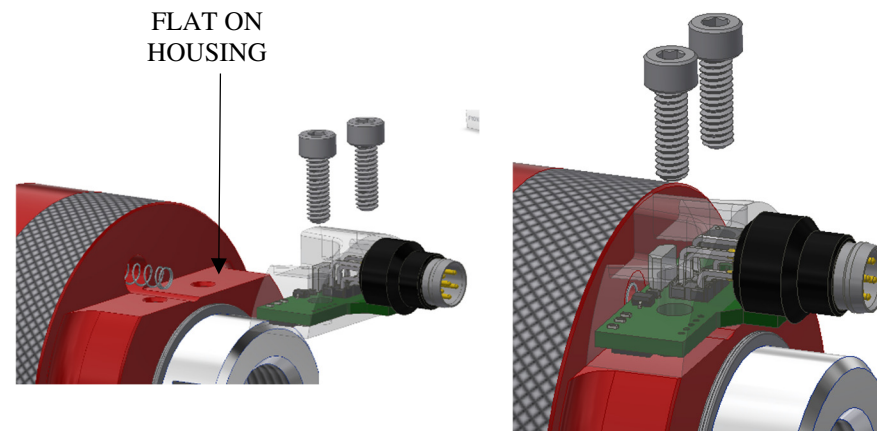

34. Install second actuator/magnet and spring components into hole on backside of the housing.

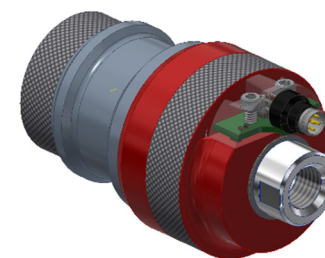
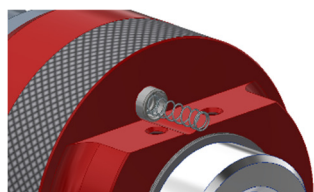
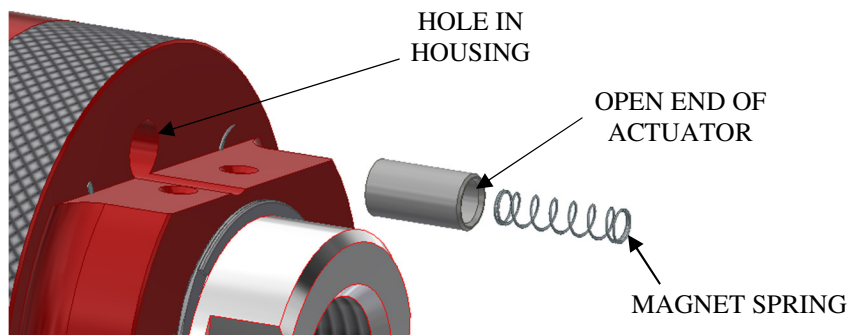

38. Verify that the assembly is operating properly by actuating the connector several times with test piece connection.
39. Connector the media supply back into the termination port and connect the Sure Seal cable back into the M8 termination.
40. If connector ICON needs to be reprogrammed see instruction WP168.

REBUILD/REPAIR INSTRUCTIONS

Page 9 of 9

